



TECHNOLOGIES REVOLVING THE WORLD



INDUSTRIAL EQUIPMENT
FOR VALVE MAINTENANCE AND CALIBRATION WORKSHOP



INDUSTRIAL EQUIPMENT

FOR VALVE MAINTENANCE AND CALIBRATION WORKSHOP

- Heavy duty valve test benches with range of DN from ½" up to 56" and clamping force up to 4000 tonnes
- Portable valve test and repair systems
- Mobile workshops efficiently operated in the harsh onshore climatic conditions and on the deep-water offshore installations
- Advanced product line of grinding / lapping units
- Stationary CNC and conventional type boring machines
- Welding overlaying and hard-facing automation

THE GENERAL TECHNOLOGICAL SCHEME

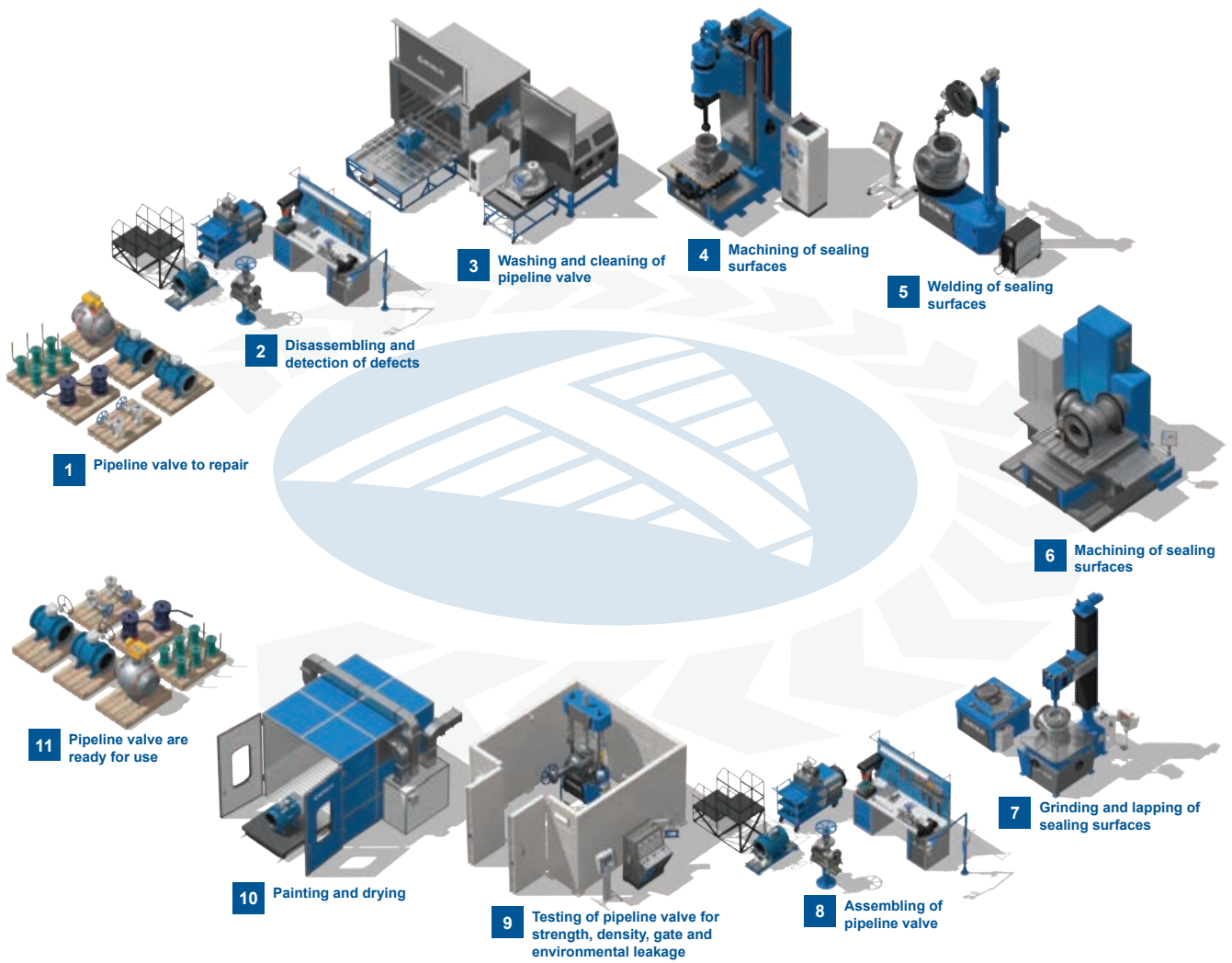

EQUIPMENT LAYOUT PLAN

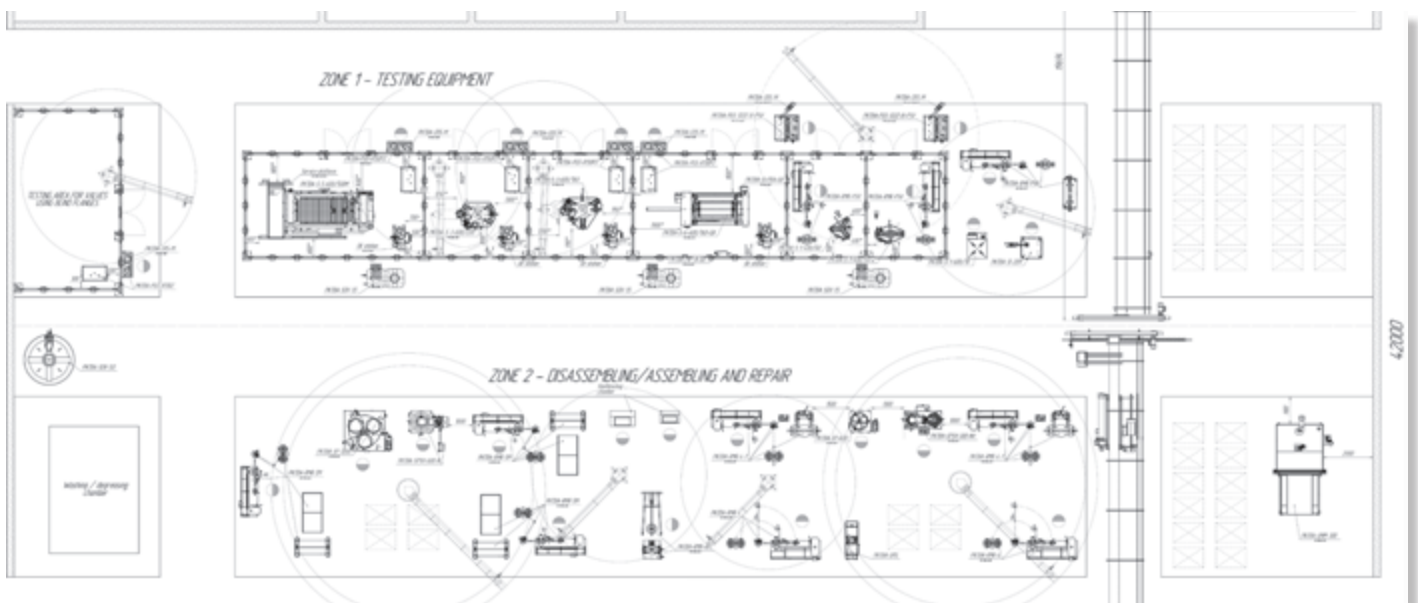

CONTENT

About company		4
EQUIPMENT FOR DISASSEMBLING-ASSEMBLING OF VALVES		
RMR		8
Welding automation		
UN		10
UNG-400-1300-800-KN		11
USKSH		12
UNG-900-1200-3000-KNV		13
UNG-KNV		14
MACHINES FOR GRINDING AND LAPPING		
SP		16
Machines and tooling for lathing (edge cutting)		
SR		17
Machines for grinding and lapping		
SPSH		18
PORTABLE MACHINES FOR REPAIR OF GATE, GLOBE & SAFETY VALVES		
PUR-K200, PUR-K150, PUR-K100K		21
PUR-1000, PUR-600, PUR-450, PUR-250		22
PUR-5		23
MOBILE WORKSHOPS		
20ft truck-mounted testing workshop for shut off and control valves		25
10ft onshore workshop for PSV testing and minor repairs		26
20ft offshore workshop for HP gas/liquid testing of shut off valves with pressure isolated operator room		27
EQUIPMENT FOR TESTING OF SHUT-OFF & CONTROL VALVES		
Horizontal test benches		
S-6-1400/4000, S-6-1400/3200, S-6-1400/2800	DN up to 1400 mm (56")	31
S-6-1200/2000, S-6-500/250, S-6-500/160	DN up to 1400 mm (56")	32
S-5-1050/1300, S-5-1000/600, S-5-800/750	DN up to 1400 mm (56")	33
S-5-600/500, S-5-600/350, S-5-500/250	DN up to 700 mm (32")	34
S-5-300/65, S-5-250/60, S-5-150/40	DN up to 400 mm (14")	35
S-5P-600/500	DN up to 600 mm (24")	36
S-5P-80/6-5	DN up to 80 mm (3")	38
Vertical test benches		
S-3-800/160, S-3-600/220, S-3-600/160	DN up to 800 mm (32")	41
S-3-600/100, S-3-500/160, S-3-500/100, S-3-500/60	DN up to 600 mm (24")	42
S-3-400/60, S-3-400/40, S-3-300/40, S-3-250/15	DN up to 400 mm (16")	43
Vertical test benches with sliding table		
S-3-500/400, S-3-400/400V	DN up to 500 mm (20")	45
Tilting test benches		
S-4-400/270, S-4-400/180, S-4-300/40	DN up to 400 mm (16")	47
Control stations		
PGS	Control stations	48
Multi-station test benches		
S-3-300/160-3...S-3-100/60-5	DN up to 300 mm (12")	51
TEST BENCHES FOR TESTING AND ADJUSTMENT OF PRESSURE SAFETY AND VACUUM RELIEF VALVES		
S-1-400/60, S-1-400/40, S-1-300/40	DN up to 400 mm (16")	53
S-1-250/15, S-1R-250/15 (mobile stand)	DN up to 250 mm (10")	54
MP-SRV-40	DN up to 300 mm (12")	56
Breather valves testing unit		
S-1-600/10	DN up to 600 mm (24")	59
Test bench for testing safety valves springs		
SI-25M	DN up to 300 mm (12")	60
Portable measuring systems		
D-14-EX	portable measuring systems	61
COMPLEX FOR TESTING WELLHEAD EQUIPMENT AND BLOWOUT PREVENTERS		
SI-PVO		
	Complex for testing	62
UNIT №1	DN up to 280 mm (11")	64
UNIT №4	DN up to 425 mm (17")	65
UNIT №5	DN up to 425 mm (17")	66
OPTIONAL EQUIPMENT		
CRS-M	Computer registration system	68
UK	Automated compressor units	70
SOV	Recycling water supply station	71
VU	Vacuum system	71
B	Safety fence	72
SI-PRA	Test unit	73
BR, MIP-W, MIP-A	Leakage measuring unit	73
MG	Hydraulic drive unit	74
MSSH	Muffler for high pressure PSV gas testing	74
OUR CERTIFICATES		
		75
CONTACT		
		75

OUR TEAM

Continuous work of several generations of our employees promoted the REVALVE leadership in the industry. Currently REVALVE employs over than 900 highly educated specialists.

Commercial department is focused on the best customer service and contract follow-up, starting from the moment of client's inquiry up to the equipment installation and start-up.



ENGINEERING DEPARTMENT

More than 90 talented engineers of our engineering department create design of the latest equipment versions, as well as special customized equipment editions.

Supreme quality of our products is achieved by using a professional software package such as three-dimensional modeling system Compass-3D, Solid Works and integrated automatic design system Altium Designer, which help us to reduce cost, improve product quality and accelerate the production cycle.

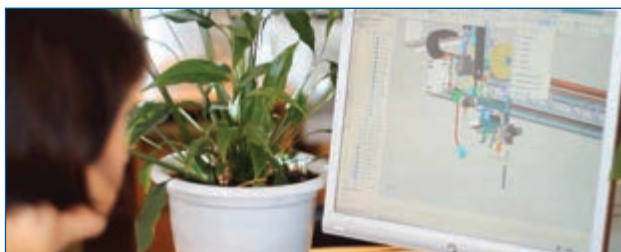

PRODUCTION CYCLE

REVALVE product range undergoes all technological stages of manufacturing and is constantly updated and upgraded. Our in house production base is equipped with more than 250 units of the most modern equipment and CNC machining centers.

- Raw material section of the workshop provides cutting of round bars and profiled metal by semi-automatic belt-type cutting machines, as well as cutting of rolled and sheet metals achieved by CNC gas-oxygen torch cutting center.
- Heat treatment of parts is carried out in batch-type and shaft furnaces.
- Mechanical processing workshop performs fabricating of a threaded screws and gear wheels. All of the machining operation is made on the high-duty machines.
- Welding and surface hardfacing operations by carbon and alloy steels, non-ferrous metals and alloys are performed by highly qualified and certificated specialists.
- Before coating, equipment parts are cleared from rust and slag in the shot-blasting camera.
- Painting section is equipped with brand new heat drying camera, which provides a supreme quality of the paint coating.
- Assembling of the equipment is carried out in the shortest possible terms.



QUALITY CONTROL

Our QMS system has been certified as per latest edition of international QMS standards ISO 9001, 14001, 45001. All manufactured equipment is properly tested, according to the program and test procedures. Testing process takes place in the safety bulletproof enclosure, which ensures safety of operating personnel.

Quality control has always been an essential element at every stage of manufacturing. All the outsourced parts and materials undergo 100% incoming control.

In **REVALVE** all parts used in the production cycle are tracked by using the bar-coding system, which provides identification and traceability of each component of the products during manufacturing process. For the dimension control of machined parts we use traditional measurement devices and coordinate measuring machine **ABERLINK**.

Our product range complies with national and international standards and is certified in accordance with requirements of EN 60204-1, EN ISO 12100, EN 2006/42/EC, EN 2004/108/EC, EN 2006/95/EC, and supplied with CE marking and declaration of conformity with EU requirements.

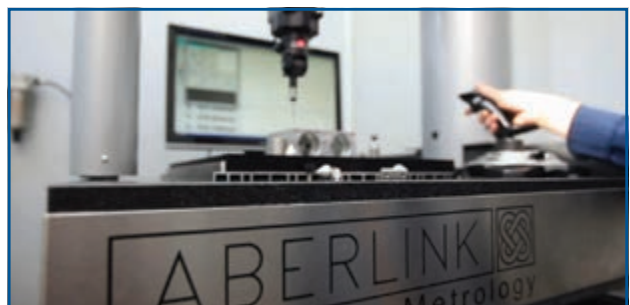

WARRANTY AND AFTER SALES SERVICE

Our service policy offers 18 months of warranty and post-warranty service for the supplied equipment. Our company attaches the utmost importance to appropriate training of future equipment operators to ensure safe operation and maintenance of supplied equipment.

REVALVE is a client oriented company and our customer care policy is based on a long term partnership with our esteemed clients. **REVALVE** service department is always ready to perform immediate after sale service of supplied equipment.

Equipment ordered from **REVALVE** is always fitted out with spare parts, tools, and accessories.

Through the decades **REVALVE** supplies products to the largest enterprises of Russia, CIS, Europe, Africa and South-East Asia.

Cooperating with **REVALVE** is the guarantee of reliable and safe operation of your business!

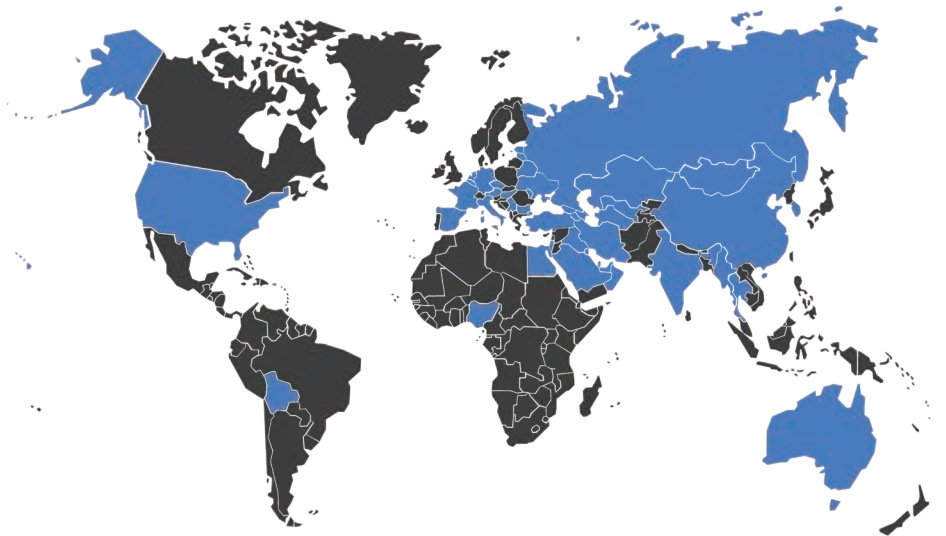

PROJECT ENGINEERING OF VALVE TESTING AND REPAIR FACILITIES

With **REVALVE** machines and know-how based on more than 60 years history of successful projects implementation, we can offer our customers cutting edge technologies by leveraging **REVALVE**'s knowledge base and our vast experience in valve repair and testing equipment manufacturing and valve service solutions.

REVALVE has the unique advantage of being the only valve repair and testing equipment manufacturer capable to provide the know-how, required for setting up a valve repair and testing workshop with all required equipment from one manufacture.

Our leadership in this field in more than **60 years** of machine manufacturing experience, engineering and realization of valve repair and testing workshops projects for wide range of industry sectors worldwide.

REVALVE engineering service offers a complete solution for:

1. Selection of equipment as per customer operation requirements.
2. Workshop general processes.
3. Equipment layout and foundation plan for equipment installation.
4. Power and source supply engineering.
5. Manufacturing of valves overhauling equipment.
6. Engineering of turnkey workshop projects.
7. Installation start up and training of equipment operators.
8. Customized equipment engineering and manufacturing.

More than 90 highly qualified engineers of **REVALVE** are always ready to support our esteemed clients at the initial project stage, with our vast variety of engineering service packages, to ensure project implementation from its beginning to equipment installation and start up.

Our commitment is improving of long term, safe and reliable operation of valve maintenance facilities at the end users' sites.

RMR

WORK STATION FOR VALVES ASSEMBLING/DISASSEMBLING DN 15...1200 mm (1/2...48")

PURPOSE:

- **RMR-4, RMR-5** - disassembling and assembling of the wedge, stop, control, and shut-off valves.
- **RMR-4-1** - disassembling and assembling and performing preliminary pneumatic tests of the wedge, stop, control, and shut-off valves with pressure up to 6 bar (90 psi).
- **RMR-6** - disassembling and assembling of the wedge and parallel-seat gate valve.
- **RMR-PSV** - disassembling and assembling of the safety valves.
- **RMR-SH** - disassembling and assembling of the slab gate valves.
- **RMR-AFK** - disassembling and assembling of the wellhead valves (Cross-type Christmas Tree).
- **UPG** - unit is designed for nuts unscrewing, screwing, and cutting (when impossible to unscrew).
- **TGR** - mobile trolley for valve transportation.

OPTIONAL:

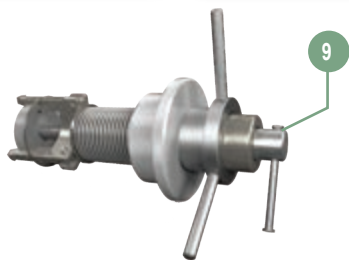

FEATURES:

- RMR is a set of accessory equipment to ensure fast and efficient disassembly and assembly of pipeline valves.
- Work bench with lockers, safety screen and lamp (1).
- Bench for disassembly and assembly of pipeline valves DN 15...300 mm (1/2...12") and safety valves (2).
- For convenience, bench is adjustable in height.
- Bench for disassembly and assembly of pipeline valves with nominal bore DN 350...600 mm (14...24") (3).
- For convenience, bench is equipped with a ladder (4).
- Bench for preliminary pneumatic tests of the pipeline valves DN 50...350 (1/2...14") mm (5).
- Rack for oil station (6).
- Stand with swinging boom, balance beam, replaceable screwdrivers and air preparation unit (7).
- Hydraulic press for pressing-in (pressing-out) of slab gate valves bushings (8).
- Device for compressing disk springs of slab gate valves (9) – 2 pcs.
- Drilling machine for repair jobs (10).
- Vice (11).
- Stand with pneumatic screwdriver for installation and fixing of the Christmas Tree valves (12).
- Height-adjusted movable support (13).
- Hydraulic crane with lifting capacity 500 kg (14).
- Each work station delivery set includes a fitting tool kit (15), rechargeable flashlight (16), and first aid kit (16).
- Stand for safety valves disassembly/assembly (17).
- Bench for disassembly and assembly of pipeline valves DN 700...1200 mm (28...48") (18). For convenience, the bench is equipped with a repair platform (19).

SPECIFICATIONS:

Model	Usable range DN, mm (")
RMR-4	15...300 (1/2...12)
RMR-4-1	50...300 (2...12)
RMR-5	15...600 (1/2...24)
RMR-6	700...1200 (28...48)
RMR-PSV	15...300 (1/2...12)
RMR-SH	65, 80 (2 1/2, 3)
RMR-AFK	65 (2 1/2)

RMR

WORK STATION FOR VALVES ASSEMBLING/DISASSEMBLING DN 15...1200 mm (1/2...48")

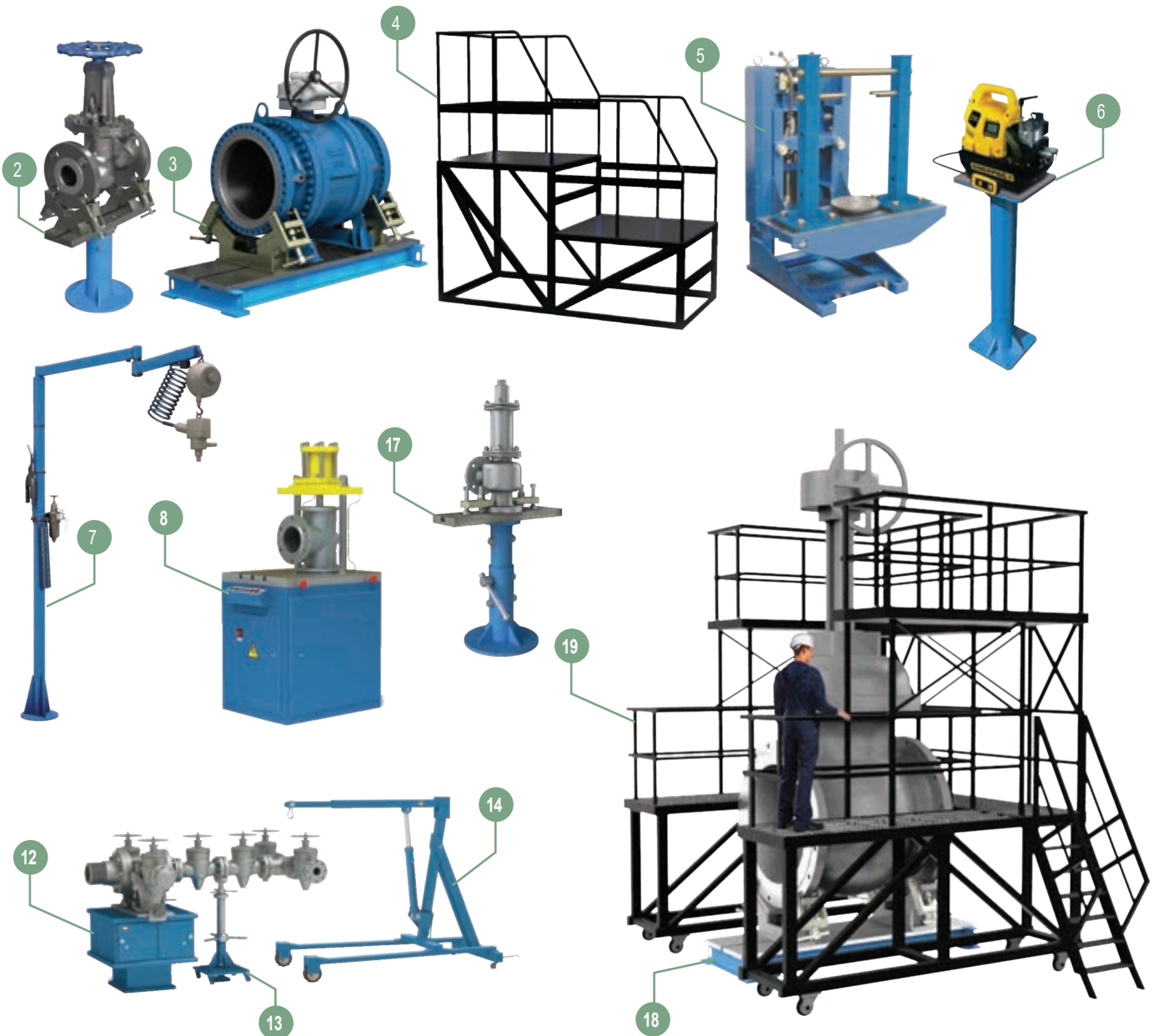

COMPLETE SET:

COMPLETE SET	RMR-4	RMR-4-1	RMR-5	RMR-6	RMR-PPK	RMR-SH	RMR-AFK
Work bench with lockers and safety screen (1)	+	+	+	+	+	+	
Bench (2)	+	+	+				+
Bench (3)			+				
Ladder (4)			+				
Bench for preliminary pneumatic tests up to 6 bar (90 psi) (5)		+					
Rack for oil station (6)		+					
Stand with swinging zigzag boom and pneumatic screwdriver (7)	+	+	+		+	+	
Hydraulic press (8)							+
Device for compressing the disk springs of the gate valves (9)							+
Bench drilling machine (10)	+	+	+	+	+	+	+
Vice (11)	+	+	+	+	+	+	+
Stand (12)							+
Movable support (13)							+
Hydraulic crane (14)							+
Fitting tool kit (15)	+	+	+	+	+	+	+
Rechargeable flashlight (16)	+	+	+	+	+	+	+
First aid kit (16)	+	+	+	+	+	+	+
Stand for safety valves disassembly/assembly (17)					+		
Bench for disassembly/assembly of the wedge and parallel-seat gate valve (18)				+			
Repair platform (19)				+			

MACHINE FOR HARDFACING, CLADDING AND REBUILDING OF PIPELINE VALVES TRIM COMPONENTS AND PARTS DN 50...1200 mm (2...48")

PURPOSE:

- automated hardfacing / cladding of valve trim components and sealing elements with diameter from 50 up to 1200 mm (2...48") with(out) oscillation in submerged arc process or in shielding gases (SAW, GMAW, GTAW, FCAW processes) with full wire or flux-cored wire.

SAW - Submerged arc welding
GMAW - Gas metal arc welding
GTAW - Gas tungsten arc welding
FCAW - Flux-cored arc welding

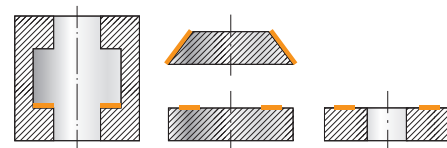
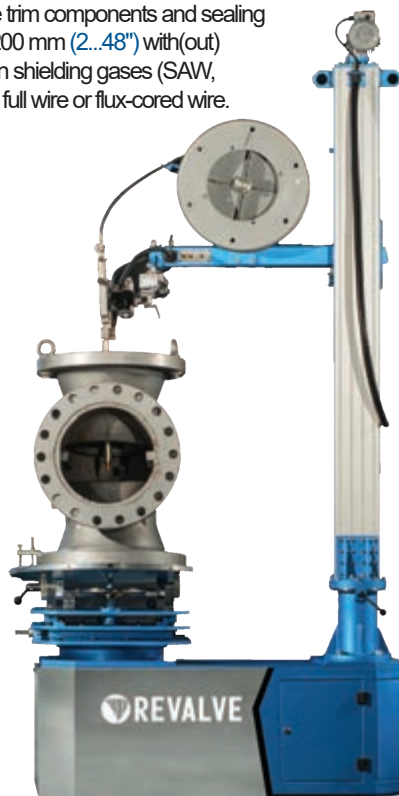

Weld pad

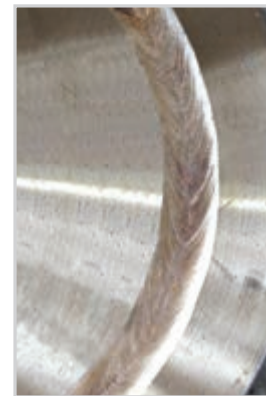

FEATURES:

- Machine is equipped with forced cooling of the welding unit and bended water-cooled torch.
- Oscillating mechanism allows to increase the hardfacing layer up to 60 mm (2³/₈").
- Advanced construction of rotator allows to fix processed part in three coordinates (tilt angle and position along the x and y axes).
- Machine control system is based on industrial controller thus allowing operator to set hardfacing / cladding parameters (oscillation amplitude, amplitude velocity, number of faceplate revolutions, etc.) through a touch screen control panel.
- Unit is equipped with remote controller.
- Fast change of welding method (not more than 10min).
- Set of spare parts includes a set of tools, wearing parts kit and first aid kit.
- Hardfacing zone backlighting.
- Machines allows to perform hardfacing/overlaying of internal cylindrical surfaces and welding of girth welding seams in horizontal plane (hardfacing of sealing rings, welding of flanges).*
- Machines allows to reach hardfacing of 60 HRC and above.**
- Welding sources of any manufacturers are applicable.

SPECIFICATIONS:

Parameter	UN-1G(F)		UN-2		UN-3	
	G	F	G	F	G	F
Valve range, DN, mm (")	50...300 (2...12)		50...600 (2...24)		300...1200 (12...48)	
Faceplate rotation speed, rpm	0,08...4,5				0,0125...1,25	
Tilt angle of the table, degrees			0...10			
Arc protection method			gas (flux)			
Power supply, V/Hz			400/50 (480/60*)			
Welding current, A			up to 1000			
Electrode-wire diameter, mm (")	1,2...1,6 (0,039...0,063)	2...4 (0,079...0,197)	1,2...1,6 (0,039...0,063)	2...4 (0,079...0,197)	1,2...1,6 (0,039...0,063)	2...4 (0,079...0,197)
Wire feed rate, m/h (in/h)	100...1200 (3937...47244)	50...400 (1969...15748)	100...1200 (3937...47244)	50...400 (1969...15748)	100...1200 (3937...47244)	50...400 (1969...15748)
Capacity, kg/h	up to 5	up to 15	up to 5	up to 15	up to 5	up to 15
Overall dimensions, mm (")	1735x1015x3495 (68x40x137)		1765x1015x3495 (69x40x137)		4090x2030x5630 (161x80x222)	
Weight (machine/power source/control panel), kg	1200/95/85		1030/105/85		6235/95/85	

* Upon customer request.

** While using appropriate welding materials.

UNG-400-1300-800-KN

MACHINE FOR HARDFACING, CLADDING AND REBUILDING OF ROTATING BODIES

PURPOSE:

- automated hardfacing/cladding of shafts, spindles and rods with diameter of up to 400 mm (16") in shielding gases (GMAW, GTAW, FCAW processes).

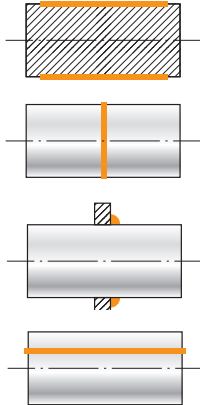

SAW - Submerged arc welding
GMAW - Gas metal arc welding
GTAW - Gas tungsten arc welding
FCAW - Flux-cored arc welding

FEATURES:

- Machine is equipped with forced cooling of the welding unit and bended water-cooled torch for welding of fillet welds.
- Machine allows hardfacing/cladding of cylindrical parts with length up to 1250 mm (49").
- Machine control system is based on industrial controller thus allowing operator to set hardfacing/cladding parameters (oscillation amplitude, amplitude velocity, number of faceplate revolutions, etc.) through a touch screen control panel and perform welding process in automatic mode.
- Oscillating mechanism provides greater performance of the hardfacing/cladding process.*
- Machine allows to perform hardfacing/cladding of cylindrical surfaces and welding of girth seams with automatic filling of the cutting edge.*
- Machine can be equipped with an additional (second) welding head to provide its greater performance.

SPECIFICATIONS:

Parameter	UNG-400-1300-800-KN
Valve range, DN, mm (")	50...400 (2...16)
Maximum weight of welded part, kg	800
Maximum length of the welded area, mm (")	1000 (39)
Maximum length of installed part, mm (")	1300 (51)
Vertical travel of welding head, mm (")	180 (7)*
Horizontal travel of welding head, mm (")	1500 (59)
Welded part rotation speed, rpm (continuously adjustable)	0,05...3
Horizontal travel of welding head along welding seam, mm (")	±50 (±2) (2)
Tailstock displacement, mm (")	1300 (51)
Amount of the quill movement, mm (")	80 (3)
Arc protection method	gas
Core wire diameter, mm (")	1,0; 1,2; 1,6 (0,039; 0,047; 0,069)
Rated welding current at 100% duty cycle (40 ° C), A	450
Power supply, V/Hz	400/50
Overall dimensions (machine/power supply unit) (LxWxH), mm (")	2700x1845x2250/740x300x460 (106x73x89/29x12x18)
Weight (machine/power supply unit), kg	1000/42,1

* Upon customer request.

USKSH

WELDING UNIT FOR GIRTH SEAM WELDING OF PIPELINE PARTS DN 15...1400 mm (½...56")

PURPOSE:

- girth seam welding of ball valves with diameter from 15 up to 1400 mm (½ ... 56") in MIG/MAG process.

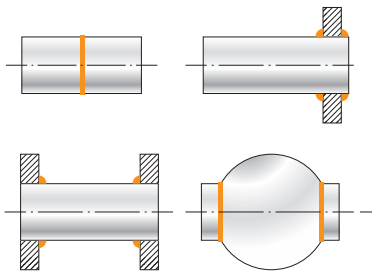

SAW - Submerged arc welding
GMAW - Gas metal arc welding
GTAW - Gas tungsten arc welding
FCAW - Flux-cored arc welding

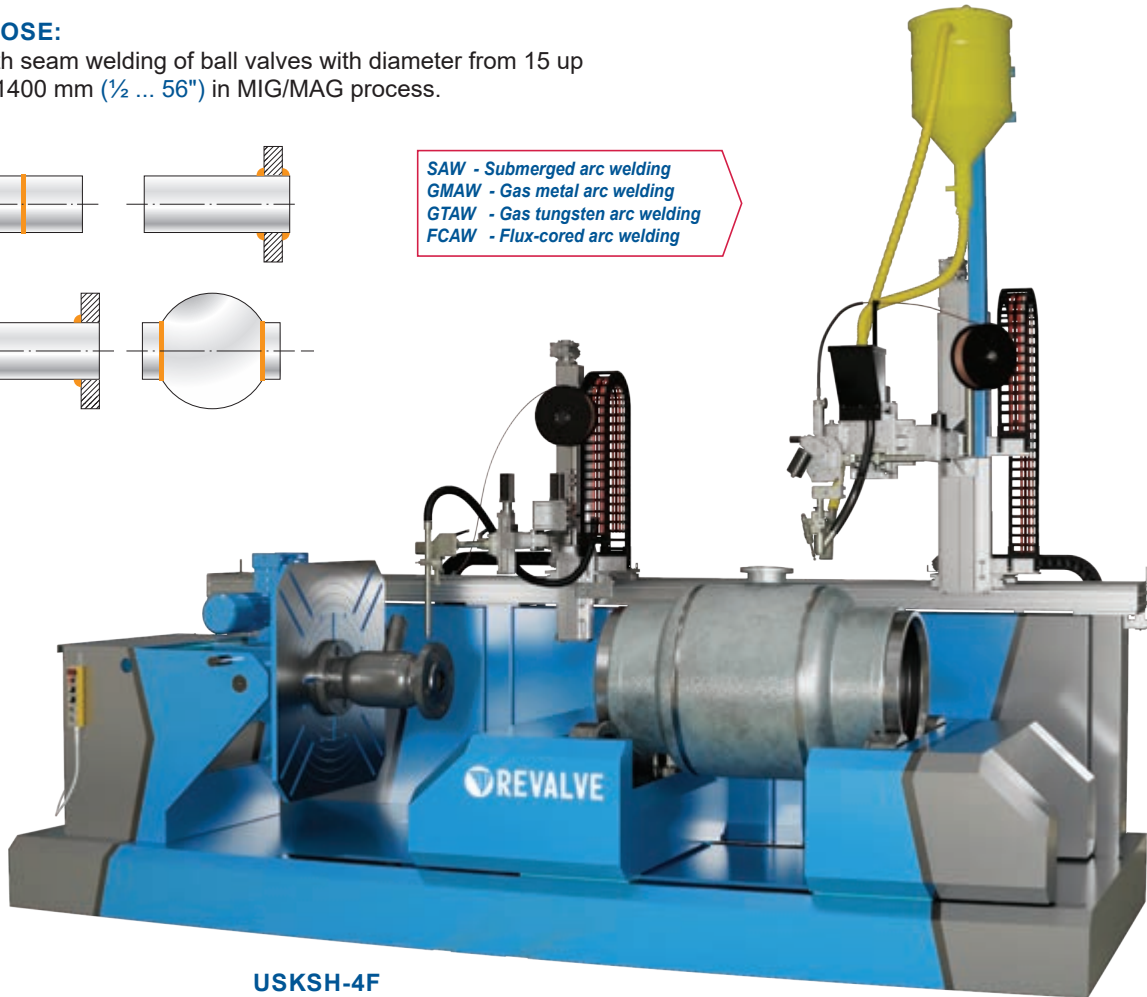

USKSH-4F

FEATURES:

- Simultaneous operation of two welding heads provides high performance of the unit.
- Standard unit set includes: rotator, gantry, two welding heads and two welders.
- Tilting rotator face-plate.
- Continuous adjustment of welding speed.
- Control systems of the units are based on industrial controller, thus allowing operator to set welding parameters (welding speed, number of faceplate revolutions etc.) while using control touch panel.
- Welding units can be optionally completed with the following accessories:*
 - flux recovery system (for "F" version);
 - seam tracking system;
 - oscillating mechanism;
 - water recycling station (SOV);
 - video control system;
 - idle roller bed;
 - welding sources of any manufacturers.
- Simplicity and ease of operation.

SPECIFICATIONS:

Parameter	USKSH-1G	USKSH-2G(F)	USKSH-3G(F)	USKSH-4F
Valve range, DN, mm (")	15...125 (½...5)	150...350 (6...14)	300...700 (12...28)	700...1400 (28...56)
Load capacity including the device, kg	500	2000	10000	30000
Welding head number, pcs			2	
Arc protection	gas	gas (flux)	gas (flux)	flux
Diameter of electrode wire, mm (")	1,0; 1,2; 1,6 (0,039; 0,047; 0,069)	1,0; 1,2; 1,6 (2...4) (0,039; 0,047; 0,069) (0,079...0,157)	1,2; 1,6 (2...5) (0,047; 0,069) (0,079...0,2)	2...5 (0,079...0,2)
Rated welding current, at 100% duty cycle, A	350		1000	
Overall dimensions (LxWxH), mm (")	2150x2000x2600 (85x79x102)	2500x2200x2800 (98x86x110)	3000x2500x3100 (118x98x122)	8200x7000x6000 (323x275x236)

* Upon customer request.

UNG-900-1200-3000-KNV

AUTOMATED SYSTEM FOR BALL VALVE TRIM COMPONENTS HARDFACING/CLADDING AND REBUILDING DN 50...600 mm (2...24")

PURPOSE:

- automatic GTAW hardfacing / cladding of surfaces of ball valve trim components.

SAW - Submerged arc welding
GMAW - Gas metal arc welding
GTAW - Gas tungsten arc welding
FCAW - Flux-cored arc welding

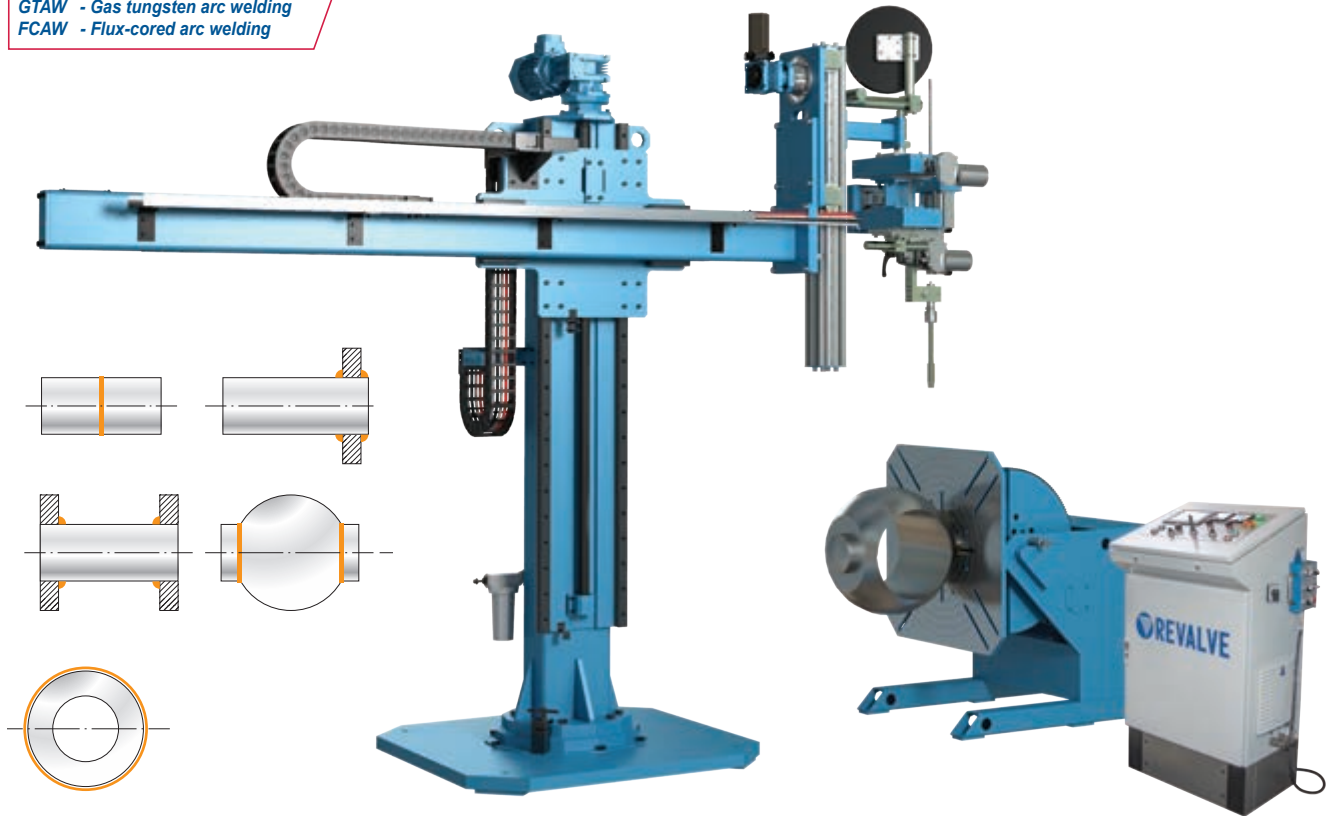

FEATURES:

- Machine implies using a variety of hardfacing/cladding methods of the metal layers. Such, as: GMAW, SAW, SAW strip cladding. Wide range of mentioned variants provides flexibility in the equipment application for various technical tasks.
- Width of hardfacing can reach 60...90 mm (2"...3") after one pass. That leads to significant increase in hardfacing/cladding productivity.
- Completely programmable course of the torch movement relative to the overlaid plug minimizes the influence of human factor on the welding result.
- Optionally: systems of video surveillance and storage of data received during the welding process.
- Application of high-precision slideways, modules of linear movement, ball screws allows to increase frequency of coordinate movement.
- Optional devices for ball valve body circular welding are available upon request.

SPECIFICATIONS:

Parameter	UNG-900-1200-3000-KNV
Maximum weight of processed parts, kg	2000
Internal diameters of processed parts, mm (")	50...600 (2...24)
External diameters of processed parts, mm (")	up to 900 (35)
Maximum length of processed parts, mm (")	up to 1000 (39)
Welding current at 100%, A	350
Overall dimensions (LxWxH), mm (")	5100 x 2500 x 4500 (200x98x177)
Weight, kg	5000

UNG-KNV

MACHINE FOR HARDFACING/CLADDING AND REBUILDING OF CYLINDRICAL AND FLAT VALVE SURFACES

PURPOSE:

- automated hardfacing/cladding of external and internal surfaces of cylinders in shielding gases or by flux-cored wire (GMAW, FCAW).

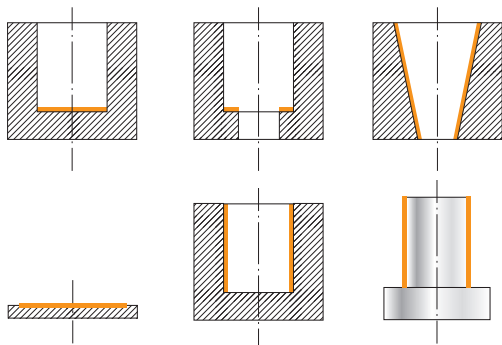

SAW - Submerged arc welding
GMAW - Gas metal arc welding
GTAW - Gas tungsten arc welding
FCAW - Flux-cored arc welding



UNG-750-400-400-KNV-A

FEATURES:

- Compact size.
- Machine control system allows to program the unit to perform hardfacing/overlaying of several part types.
- Hardfacing/overlaying process may consist of several passes with different hardfacing rate, presence of transverse oscillation, different oscillation parameters (range, speed etc.).
- Automation of hardfacing/cladding process provides higher quality of the cladded surface, excluding human factor.
- Possibility of flat surfaces hardfacing/cladding.
- Minimum internal diameter of processed part is 16 mm ($\frac{1}{2}$ ").
- Water-cooled welding head.

UNG-KNV

MACHINE FOR HARDFACING/CLADDING AND REBUILDING OF CYLINDRICAL AND FLAT VALVE SURFACES

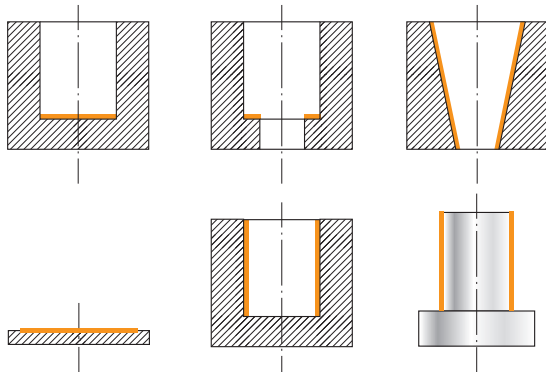

SAW - Submerged arc welding
 GMAW - Gas metal arc welding
 GTAW - Gas tungsten arc welding
 FCAW - Flux-cored arc welding



UNG-850-850-1000-KNV

SPECIFICATIONS:

Parameter	UNG-750-400-400-KNV-A	UNG-850-850-1000-KNV
Horizontal travel of welding head, mm (")	550 (22)	1400 (55)
Travel of a welding head along "zenith", mm (")	100 (4)	100 (4)
Vertical travel of a welding head, mm (")	400 (16)	1000 (39)
Rotator load capacity, kg	400	300
Rotator faceplate rotation speed, rpm	0,05÷7	0,2÷5
Tilt angle of a rotator faceplate, deg.	0÷50	-
Electrode-wire diameter, mm (")	1,6; 2,8 (0,069; 0,11)	1,0; 1,2; 1,6 (0,039; 0,047; 0,063)
Rated welding current, at 100% duty cycle, A		420
Welding current adjustment range, A		5÷450
Range of welding voltage, V	15÷35	15÷31
Arc protection method		gas
Maximum power consumption, kW	35	45
Power supply, V/Hz		400/50
Overall dimensions, (LxWxH), mm ("):		
- machine;	1800x1050x2665 (71x41x105)	2295x1508x2845 (90x59x112)
- power source.	1100x455x950 (44x18x37)	1100x455x1000 (43x18x39)
Weight (machine/power source), kg	970/125	1220/129

PURPOSE:

- machine is designed for lapping (polishing) of the flat sealing surfaces of the gate valve wedges, valve spools, and christmas-tree valves wedges;
- special-configuration SP-600 is used for lapping of the end-seal rings.

TYPES OF MACHINED PARTS:

- wedges of the gate and christmas-tree valves;
- valve (global valve) spools;
- end-seal rings of the pumps;
- other flat-surface parts.

LAPPING-PLATE DIAMETER:

- **SP-1200:** Ø 1250 mm (49"). Approximately, DN 50...600 mm (2...24") for the wedges of the gate valves, and DN 40...200 mm (2...8") for the valves spools.
- **SP-1000:** Ø 1000 mm (39"). Approximately, DN 50...500 mm (2...20") for the wedges of the gate valves, and DN 50...200 mm (2...8") for the valves spools.
- **SP-600:** Ø 620 mm (24"). For gate valves wedges DN 50...150 mm (2...6").
- **SP-400:** Ø 380 mm (15"). For gate valves wedges DN 10...100 mm (½...4").



SP-1200



SP-600

FEATURES:

- Each point of the lapped surface of the parts makes complex plane-parallel motion on the lapping-plate surface.
- The machines are equipped with the polishing-compound supply device.
- Used compound is collected in a special tank.
- Lapping time is automatically controlled by the timer.
- Machine is equipped with smooth start device with lapping-plate speed adjustment.
- Machine is designed so that the lapping disc can be adjusted during its operation.

SPECIFICATOIN:

Parameter	SP-1200	SP-1000	SP-600	SP-400
Valve range, DN, mm (")	50...600 (2...24)	50...500 (2...20)	15...150* / 50...150** (½...6* / 2...6**)	10...100 (¾...4)
Lapping-plate diameter, mm (")	1250 (49)	1000 (39)	620 (24)	380 (15)
Number of cartridges		3 / 1		3
Internal diameter of the cartridges, mm (")	550 / 830 (21 / 32)	478 / 672 (19 / 26)	266 (10)	140 (6)
Machined-surface roughness, µm			0,08...0,1	
Machined-surface nonflatness (accuracy), mkm			0,6	
Lapping-plate speed, rpm	5...40	10...60	10...50	10...70
Power consumption, kW	8	4,5	4	0,5
Electric power supply, V/Hz		400/50		230/50
Working pressure of network air, bar (psi)	6 (91)		-	
Overall dimensions (LxWxH), mm (")	1990x1650x1350 (78x65x53)	1650x1500x1265 (65x59x50)	1200x950x1280 (47x37x50)	710x650x480 (28x26x19)
Weight, kg	2100	1410	630	125

* Upon customer request.

** Valve spools.

SR

SPECIALIZED BORING MACHINE FOR MACHINING OF VALVE TRIM COMPONENTS DN up to 1200 mm (48")

PURPOSE:

- machining (drilling, boring, milling) of pipeline valves, including main-line and middle flanges, sealing faces of bodies and gate wedges, flanged and welded ends, DN up to 1200 mm, NPS (48").

MACHINED ITEMS:

- flat metal seated valve bodies and closure sealing elements surfaces.

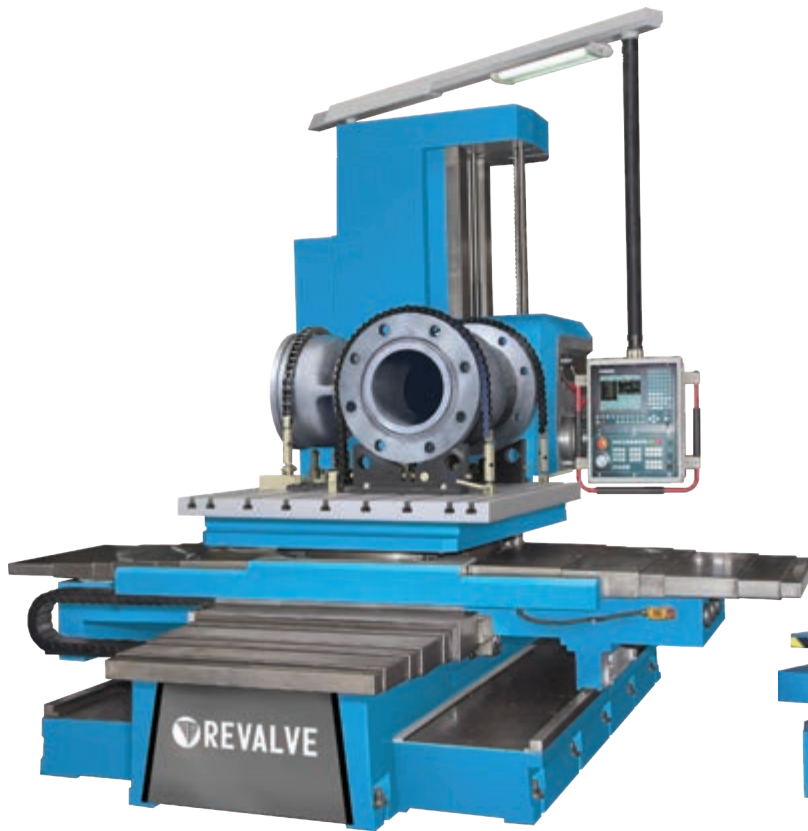

SR-1200



SR-800

FEATURES:

- Specialized valve trim machining centers with automated and conventional control systems.
- Ensures high accuracy machining of both valve body sealing faces and flanges at one set.
- Allows processing of various type work pieces within table working surface.
- Scope of supply includes the set of special set of cutting and measuring tools for valves machining and accurate positioning.
- CNC system provides 4-axis control (X, Y, Z, and W) and automated table tilting, allowing advanced machining of sealing faces at various angles.
- Preset technological programs provides fast and convenient adjustment of the machine for certain work piece machining.*
- Positioning and clamping devices ensure quick installation on the worktable.
- Tailored vertical design allows to save workshop space.

SPECIFICATIONS:

Parameter	SR-1200	SR-800	SR-600	SR-400
Valve range, DN, mm (")	600...1100 (24...43)	50...800 (2...32)	50...600 (2...24)	50...400 (2...16)
Spindle diameter, mm (")	130 (5)	-	110 (4)	110 (4)
Cone cavity of the spindle	ISO 50	-	ISO 50	ISO 50
Table transverse travel, mm (")	2000 (79)	±100 (4)	1600 (63)	1250 (49)
Table longitudinal travel, mm (")	2000 (79)	±120 (5)	1400 (55)	1400 (55)
Support motion, mm (")	120 (5)	100 (4)	180 (7)	180 (7)
Vertical travel of spindle head, mm (")	2000 (79)	1200 (47)	1200 (47)	900 (35)
Tilt angle of the table, degrees	-	±12	-	-
Table working surface, mm (")	1800x2200 (71x87)	1000x1200 (39x47)	1250x1100 (49x43)	1100x960 (43x38)
Maximum weight of processed part, kg	15000	2000	3000	2500
Power consumption, kW	82	28	12	
Electric power supply, V/Hz		400/50		
Weight, kg	60000	12500	18000	14500

* Upon customer request.

SPSH

MACHINES FOR GRINDING & LAPPING OF THE VALVE FLAT SEATS AND SEALING SURFACES DN 15...1000 mm (1/2...40")

PURPOSE:

- grinding and lapping of flat sealing surfaces (seats) of gate valves bodies and wedges, shut off and pressure safety valves body seats and spools, and other flat surfaces requiring high flatness quality.

TYPE OF VALVES:

- gate valves;
- globe valves;*
- safety valves.*

VALVES DN:

Stationary units:

- **SPSH-600-N**: DN 50...600 mm (2...24");
- **SPSH-1000-N**: DN 300...1000 mm (12...40").

Unit with two tilting tables:

- **SPSH-600-NN**: DN 50...600 mm (2...24").

Table base units:

- **SPSH-300-NN**: DN 8...300 mm (0,3...12");
- **SPSH-300-VV**: DN 8...300 mm (0,3...12");
- **SPSH-300-NV**: DN 8...300 mm (0,3...12").



SPSH-600-NN

FEATURES:

- Tilted table with adjustable angle allows operator to install the wedge valve body in a horizontal position according to the angle of seats V-camera, for fine grinding and lapping of sealing surfaces at various angles.
- Coordinate device ensures part installation by three coordinates (tilt angle and positioning as per x and y axes).
- To simplify part installation the column can turn on 290° relative to its base.
- Includes digital indication of spindle rotational speed.
- Tool drawer included in the set of unit supply allows to store replaceable accessories.
- Set of flat grey cast iron lapping plates and eccentric stem adapter allows achieving high flatness of the surface.
- Two tables version of the machine allows to process valve parts on the first table and simultaneously install and fasten the valve on the second one (SPSH-600-NN, SPSH-300-NN, SPSH-300-VV, SPSH-300-NV).
- Rotating table with adjustable axial offset serves to increase the capacity of sealing surfaces treatment process (SPSH-300-VV).
- Lathe three-jaw chuck allows to install the valve bodies and spools of small size (SPSH-300-VV, SPSH-300-NV).

* Upon customer request.

SPSH

MACHINES FOR GRINDING & LAPPING OF THE VALVE FLAT SEATS AND SEALING SURFACES DN 15...1000 mm (1/2...40")



SPSH-600-N



SPSH-300-NV

SPECIFICATIONS:

Parameter	SPSH-1000-N	SPSH-600-N	SPSH-600-NN	SPSH-300-NN	SPSH-300-VV	SPSH-300-NV
Valve range, DN, mm (")	300...1000 (12...40)	50...600 (2...24)			8...300 (0,3...12)	
Maximum diameter of the mounted valve flange, mm (")	1255 (50)	890 (36)			500 (19)	
Maximum face-to-face length of the mounted valve, mm (")	1750 (69)	1150 (46)			750 (30)	
Maximum weight of the mounted part, kg	2500	1000			500	
Dimensions of the table working surface, mm (")	1200x1200 (48x48)	900x900 (36x36)		500x500 (19x19)	Ø 500 (19)	500x500 / Ø 500 (19x19 / Ø 19)
Tilt angle of the table, degrees		0...12			-	0...12 / -
Spindle rotation speed adjustment				stepless		
Spindle rotation speed, rpm	10...150	14...200			10...240	
Machined surface roughness, µm				0,2...0,4		
Power consumption, kW	2,4	3		2,0		2,2
Power supply, V/Hz			400/50			
Overall dimensions (LxWxH), mm (")	2175x1550x3520 (86x61x138)	2500x950x3100 (98x37x122)	2500x900x3025 (98x41x119)	1716x1178x2588 (67x48x102)	1710x1180x2430 (67x46x96)	1596x1177x2108 (63x46x83)
Weight (with tooling package), kg	3100	1340	2120	1200	900	1200

PORTABLE MACHINES

FOR REPAIR OF GATE, GLOBE & SAFETY VALVES

PURPOSE:

- grinding and lapping of sealing surfaces of shut off and pressure safety valves shells and spools without their dismantling from the pipeline.

MACHINED-SURFACE TYPES:

- sealing surfaces of the gate valve trim and wedges, safety and globe valve trim and spools.

COMPLETE SET:

- professional pneumatic and/or electric and/or battery drives (E);
- stand for spool machining (PUR-K150);
- multi-function installation device (D);
- replaceable grinding and lapping discs;
- set of self-adhesive grinding wheels;
- air preparation unit with a sleeve for compressed air supply;
- hard case (C);
- set of spindles with the abrasive wheels based on electro-corundum;
- set of spindles coated with the boron nitride;
- set of coupling adapters for flangeless connections.

FEATURES:

- Grinding and lapping of valve's sealing surfaces directly on pipeline without dismantling valves from the pipeline.
- Small weight of the unit makes it convenient for use in hard-to-reach locations.
- Quality is achieved due to design of the working head and the mandrel, which generate complex plane parallel motion of the tool across the processed surface.
- Set includes the wedge processing unit, replaceable discs for grinding and lapping, and tool storage box.
- To ensure more reliable operation, complete set of pneumatic drive includes air preparation unit.
- Grinding wheels on the basis of the CBN and electro-corundum ensure high productivity of the process for removing part material and are highly wear-resistant. This reduces the time of grinding and lapping, extends life of the lapping surface.



PUR-KP-150

PUR-K200, PUR-K150, PUR-K100K

PORTABLE MACHINE FOR GRINDING AND LAPPING OF GLOBE & SAFETY VALVES
DN 8...200 mm (1/4...8")



SPECIFICATIONS:

Parameter	GLOBE AND SAFETY VALVES		
	PUR-K200	PUR-K150	PUR-K100K
Valve range, DN, mm (")	32...200 mm (1,26...8")	8...150 mm (1/4...6")	8...100 mm (1/4...4")
Maximum depth of the machined surface (distance from valve axis to the valve actuator flange end), mm (")	200 (8)	260 (10)	330 (13)
Pneumatic-driven machine			
Maximum disc RPM	1300	1300	1300
Drive power on 6,3 bar pressure, kW	0,83	0,7	0,7
Air consumption, l/min	1600	1000	1000
Air drive pressure, bar		6,3±0,5	
Machine with non-accumulator electric drive (wired)			
Maximum disc RPM (1st gear/ 2nd gear)		1000/2800	
Power consumption, kW		1,2	
Drive torque, N m (1st gear/ 2nd gear)		33,0/13,0	
Power supply, V/Hz		230/50	
Machine with accumulator electric drive (wireless)			
Maximum disc RPM (1st gear/ 2nd gear)		500/1700	
Drive torque, N m (1st gear/ 2nd gear)		24,0/11,0	
Weight of the machine (w/o packing), kg	7		10
Packed weight, kg	34		57

PUR-1000, PUR-600, PUR-450, PUR-250

PORTABLE MACHINE FOR GRINDING AND LAPPING OF GATE VALVES
DN 50...1000 mm (2...40")



SPECIFICATION:

Parameter	PUR-1000	PUR-600	PUR-450	PUR-250
Valve range, DN, mm (")	600...1000 (24...40)	200...600 (8...24)	80...450 (3...18)	50...250 (2...10)
Immersion depth - T, mm (")	1110 (44)	1000 (40)	900 (35)	635 (25)
Minimum size - A, mm (")	200 (8)	87 (3)	43 (1,7)	40 (2)
Electric drive:				
- power supply, V/Hz;			230 /50	
- power consumption, kW.	1,2	1,6	1,6	1,3
Pneumatic drive:				
- power, kW;	0,8	1,17	1,17	0,83
- air flow rate, m ³ /min (gl/min);			1,6 (423)	
- compressed-air working pressure, bar (psi).			6,3±0,5 (91)	
Weight, kg:				
- the heaviest mounted assembly;	115	22	20	13,6
- set.	445	190	173	49

* Upon customer request.

PUR-5

PORTABLE MACHINE FOR GRINDING & LAPPING OF GLOBE & SAFETY VALVES
DN 32...200 mm (1¼...8")



SPECIFICATIONS:

Parameter	GLOBE AND SAFETY VALVES PUR-5
Valve range, DN, mm (")	32...200 mm (1¼...8) (25...200 mm (1...8) for safety valve)
Electric drive:	
- power supply, V/Hz;	230 / 50
- power consumption, kW.	1,3
Pneumatic drive:	
- power, kW;	0,83
- air flow rate, m³/min (gl/min);	1,6 (423)
- compressed-air working pressure, bar (psi).	6,3 (91)
Maximum immersion depth into the valve housing, mm (")	200 (8)
Weight, kg:	
- the heaviest mounted assembly;	7
- set (with pneumatic and electric drive).	60

* Upon customer request.

MOBILE WORKSHOPS

PURPOSE:

- Ready-to-use mobile workshops based on sea freight containers are highly useful for valves maintenance on the end-user site or on the offshore platforms during a shutdown or if a regular on call repair is required.
- Modular design of mobile workshops allows to adopt them as per customer requirements and climatic conditions. Workshops lineup allows to solve all kind of issues with valves overhauling at sites such as high pressure testing, calibration and maintenance of different kinds of valves.

CONFORMS WITH STANDARDS:

API 526, API 527, API 598, ANCI FCI 70-2 (Class II-VI), DNV GL 2.7-1, ASME Section VIII, API RP 576, IEC 60534-4, EN 1349, API 6D, ISO 5208, etc.

AVAILABLE FUNCTIONS OF THE WORKSHOPS:

1. Disassembling/assembling of the valves.
2. Washing/sandblasting of the valve parts.
3. Testing of shut-off and control valves:
 - shell test acc. to API 598, API 6D, ISO 5208 etc.;
 - seat leakage test (cavities A to B, B to A) acc. to API 598, API 6D, ISO 5208 etc.;
 - backseat test acc. to API 598, API 6D, ISO 5208 etc.;
 - DBB/DIB test acc. to API 598, API 6D;
 - control valve seat leakage test, acc. to ANSI FCI 70.2, IEC 60534-4, EN 1349 etc.
4. Testing of pressure safety valves:
 - set pressure definition acc. to API 526, ASME Section VIII, API RP 576;
 - reseal pressure definition acc. to API 526, ASME Section VIII, API RP 576;
 - seat leakage test acc. to API 527.
5. Automatic generation of test reports.
6. Grinding and lapping of sealing surfaces.
7. Minor machining of the valve parts.

FOR CUSTOMER CONVENIENCE, WORKSHOP CAN BE EQUIPPED WITH:

1. Jib or overhead crane 0,5 ton or 1 ton capacity.
2. Heating, ventilating and air conditioning (HVAC system).
3. Armored wall between operator and testing room with door interlock.
4. Pressure isolated operator room.
5. Remote video control (CCTV).
6. Various furniture (wardrobe, chairs, table etc.).
7. Doors or gates on the sides of the workshop.
8. Portable on-site PSV testing unit.
9. Portable grinding and lapping unit.

WORKSHOPS ARE BASED ON:

- 10ft sea container;
- 20ft sea container (dry-cube and high-cube);
- 40ft sea container (dry-cube and high-cube).

UPON REQUEST, WORKSHOPS ARE CERTIFIED FOR:

- CSC for easy transportation;
- DNV GL 2.7-1 for offshore use;
- ATEX for hazardous areas use (only for container itself, not for equipment inside it).

WORKSHOPS ARE DESIGNED FOR VARIOUS CLIMATE ZONES FROM -60 TO +50 C°

20FT MOBILE WORKSHOP FOR TESTING AND REPAIR OF PRESSURE SAFETY AND VACUUM BREATHER VALVES

MM-TR20-PSV



PURPOSE:

- Mobile workshop for pressure safety and breather valves gas and liquid testing.

TESTED VALVES:

- Pressure safety, pilot-operated and impulse valves DN 10...400 mm ($\frac{3}{8}$...16").
- Breather valves DN 50...600 mm (2...24").

COMPLETE SET:

1. Clamping system for PSV DN 10...400 mm ($\frac{3}{8}$...16").
2. Control station.
3. Computer registration system.
4. High pressure compressor.
5. Workstation for PSV assembling/disassembling.
6. Lathe machine.
7. Test unit for breather valves DN 50...600mm (2...24").
8. Jib crane.
9. Armored wall.

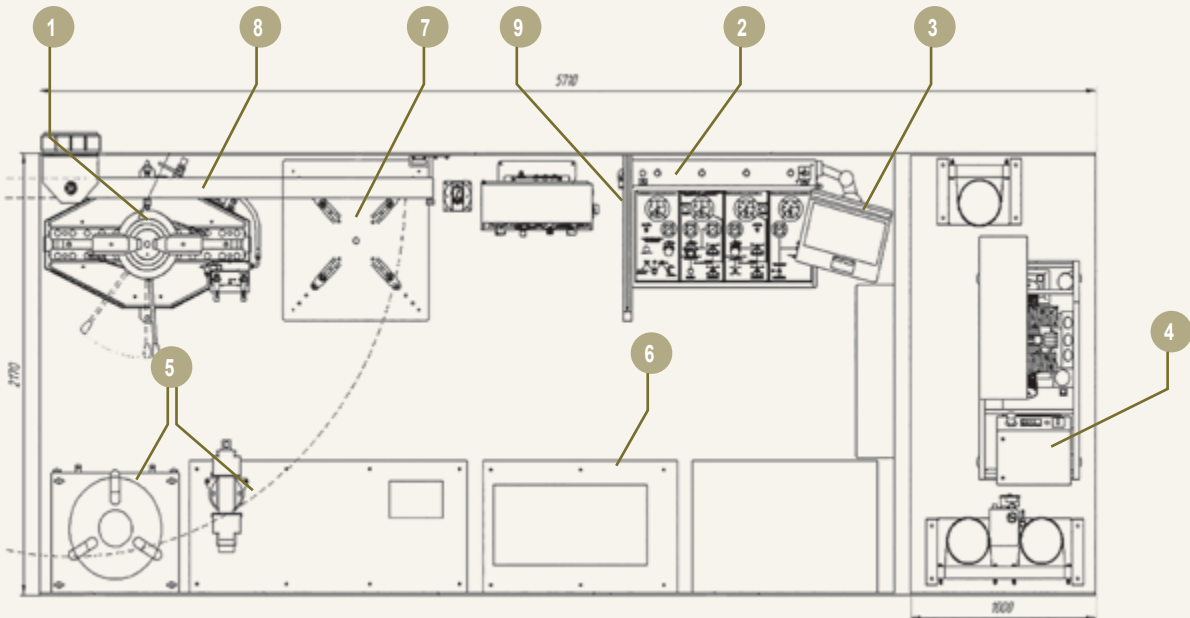

10FT OFFSHORE WORKSHOP FOR PSV TESTING AND MINOR REPAIRING

MM-T10



PURPOSE:

- Mobile workshop for PSV gas and liquid testing.
- Specialized 10ft offshore DNV 271 certified container.

TESTED VALVES:

- Pressure safety valves (PSV) DN 15...300 mm ($\frac{1}{2}$...12").

COMPLETE SET:

1. Clamping system for PSV DN 15...300 mm ($\frac{1}{2}$...12").
2. Control station with safety screen.
3. Computer registration system.
4. Jib crane.
5. Workstation for PSV assembling/disassembling.

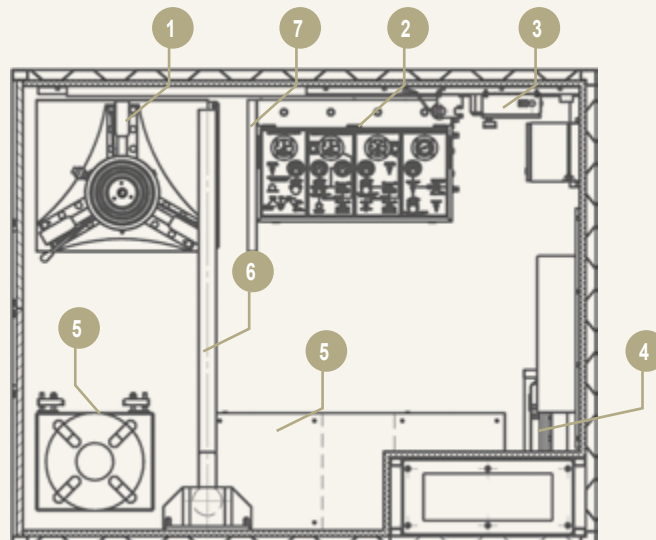

20FT OFFSHORE WORKSHOP

FOR HIGH PRESSURE GAS & LIQUID (UP TO 10000PSI) TESTING OF SHUT OFF AND CONTROL VALVES WITH PRESSURE ISOLATED OPERATOR ROOM

MM-T20



PURPOSE:

- Mobile workshop for shut off valves testing.

TESTED VALVES:

- Shut-off and control valves DN 10...250 mm ($\frac{3}{8}$...10").

COMPLETE SET:

1. Clamping system for shut off valves DN 10...250 mm ($\frac{3}{8}$...10").
2. Control station with HP booster.
3. Computer registration system.
4. Video control system.
5. Portable machine for valves grinding and lapping.
6. Jib crane.
7. Armored wall.

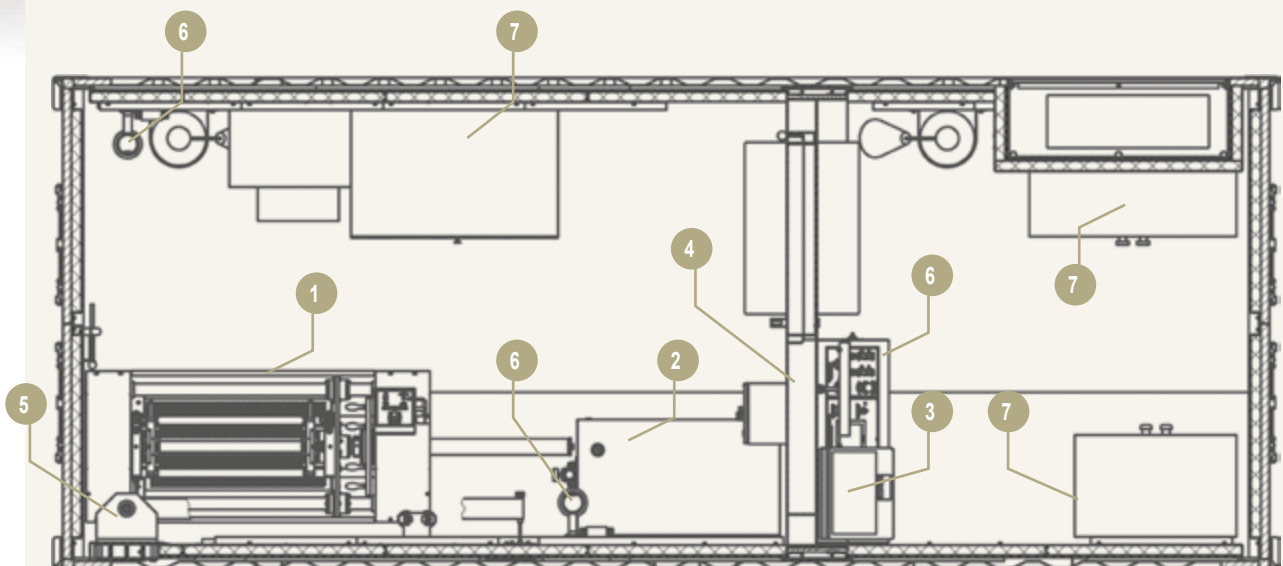

20FT MOBILE WORKSHOP

FOR HP GAS & LIQUID TESTING OF SHUT OFF, CONTROL & PRESSURE SAFETY VALVES WITH PRESSURE ISOLATED OPERATOR ROOM

MM-CTR20



PURPOSE:

- Offshore mobile workshop for shut off, control and pressure safety valves testing.

TESTED VALVES:

- Pressure safety valves DN 10...300 mm ($\frac{3}{8}$...12").
- Shut-off and control valves DN 10...250 mm ($\frac{3}{8}$...10").

COMPLETE SET:

1. Clamping system for PSV DN 10...300 mm ($\frac{3}{8}$...12").
2. Clamping system for shut off valves DN 10...250 mm ($\frac{3}{8}$...10").
3. Control station.
4. Computer registration system with air leakage measuring system.
5. Video control system.
6. Workstation for PSV assembling/disassembling.
7. Jib crane.
8. Armored wall.

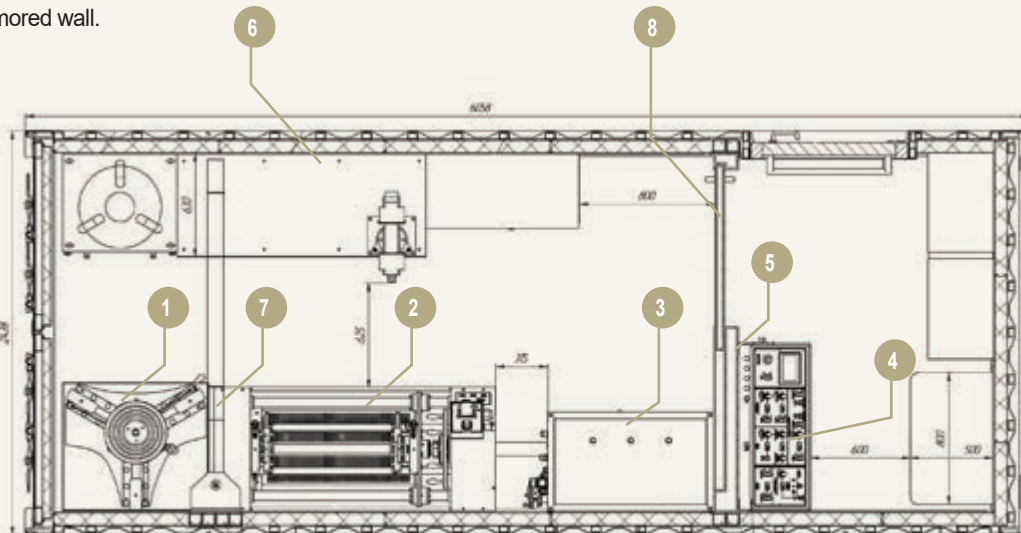

20FT MOBILE WORKSHOP

FOR HP GAS & LIQUID TESTING OF SHUT OFF, CONTROL & PRESSURE SAFETY VALVES WITH PRESSURE ISOLATED OPERATOR ROOM



VALVE TESTING EQUIPMENT

HORIZONTAL TEST BENCHES FOR HYDRAULIC AND PNEUMATIC TESTING OF SHUT OFF & CONTROL VALVES

PURPOSE:

- shell test acc. to API 598, API 6D, ISO 5208 etc.;
- seat leakage test (cavities A to B, B to A) acc. to API 598, API 6D, ISO 5208 etc.;
- backseat test acc. to API 598, API 6D, ISO 5208 etc.;
- DBB/DIB test acc. to API 598, API 6D;
- control valve seat leakage test, acc. to ANSI FCI 70.2, IEC 60534-4, EN 1349 etc.

TESTED VALVES:

- gate valves;
- ball valves;
- butterfly valves;
- check valves;
- plug valves;
- control valves.

CONNECTION TYPE:

- flanged (according to ASME B 16.5, ASME B 16.47, GOST 12815 etc.);
- welded (according to ASME B 16.25, GOST 16037, etc.);*
- set of sealing adapters available.*

FEATURES:

- Innovative PLC operated proportional clamping control system ensures accurate test results as per API standards. At the initial hydraulic cylinder stroke, pneumatic damper creates low pre-clamping force saving small sized valves bodies from damage. Cylinder actuation proportionally pre-programmed against supplied test pressure, minimizes axial load on valve body, its welding joints and sealing elements throughout the testing process, ensuring long service life of tested valves.*
- Unique design of the stainless steel multi-table adapters with groove installed sealing O-rings allow to test most of the ASME flanged valves (RF and RTJ) with all specified diameters.
- Clamping unit can be provided with radial sealing type or self-sealing adapters.*
- Bidirectional sealing during tests does not require the tested valve rearrangement, which significantly reduces the test time.
- Test bench is equipped with high-performance vacuum system, that serves for removing of air trap in the valve body providing test process safety and precise testing parameters.*
- Test bench is equipped with a stainless steel water-collection tray.
- Test preparation time is significantly reduced by using high-pressure hoses with quick-release couplings.
- Test bench is quickly adjusted to face-to-face dimensions of valve by using the hydraulically or electrically driven cross-head with remote control.
- Patented design of self-sealing adapters exclude axial compression during tests, which ensures test reliability, protects valves against deformation, and extends valves life.*
- All water-wetted parts are corrosion-proof.
- Test bench can be equipped with replaceable sealing adapters for welded ends.*
- Integrated Safety Systems include: safety interlock, overpressure protection, hydraulic oil temperature control, light indication while under pressure, emergency stop button.
- Test bench equipped with valve lifting platforms for valve positioning and support during testing.*

MAXIMUM CLAMPING FORCE CHART(T) :

DN, mm class	10 (%)	15 (1/2)	20 (3/4)	25 (1)	32 (1 1/4)	40 (1 1/2)	50 (2)	65 (2 1/2)	80 (3)	100 (4)	125 (5)	150 (6)	200 (8)	250 (10)	300 (12)	350 (14)	400 (16)	500 (20)	600 (24)	700 (28)	750 (30)	800 (32)	900 (36)	1000 (40)	1050 (42)	1200 (48)	1250 (50)	1300 (52)	1400 (56)
cl.150	15	15	15	15	15	15	15	15	15	15	15	15	15	40	40	40	65	100	100	160	160	250	350	350	350	500	500	500	500
cl.300	15	15	15	15	15	15	15	15	15	15	15	40	40	65	65	100	100	220	250	350	500	500	600	750	750	1100	1100	1100	1300
cl.600	15	15	15	15	15	15	15	15	15	40	40	40	65	100	160	220	220	350	500	750	750	850	1100	1300	1600	2000	2000	2800	2800
cl.900	15	15	15	15	15	15	15	15	15	40	40	65	100	160	220	250	350	600	750	1100	1100	1300	1600	2000	2800	2800	3200	3200	4000
cl.1500	15	15	15	15	15	15	15	40	40	65	100	100	160	220	350	500	600	850	1300	1600	2000	2800	2800	3200	4000				
cl.2500	15	15	15	15	15	15	40	40	65	100	160	160	250	350	600	750	1100	1600	2000	2800	3200	4000							

Note: Required tones of clamping force for valve shell test with test pressure 1.5 times exceeding nominal. Parameters are based on face sealing of RF flanged valves.

OPTIONAL:

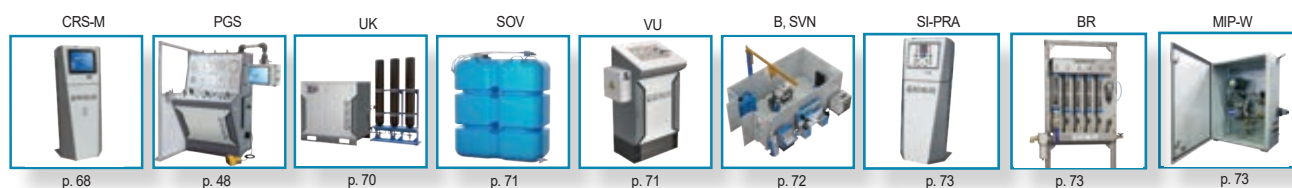

* Upon customer request.

S-6-1400/4000, S-6-1400/3200, S-6-1400/2800

TEST BENCHES FOR SHUT OFF & CONTROL VALVES DN 400...1400 mm (16...56")

S-6-1400/4000

DN, mm (")	Maximum test pressure, bar (psi)					
	cl.900		cl.1500		cl.2500	
600...800 (24...32)	235 (3400)	305 (4400)	395 (5700)	435 (6300)	530 (7600)	630 (9100)
900 (36)						#
1000 (40)						
1050 (42)						
1200 (48)						
1400 (56)						

S-6-1400/3200

DN, mm (")	Maximum test pressure, bar (psi)						
	cl.600		cl.900		cl.1500		cl.2500
500...700 (20...28)	185 (2600)	240 (3400)	315 (4500)	345 (5000)	420 (6000)	595 (8600)	630 (9100)
800 (32)							#
900 (36)							
1000 (40)						#	
1050 (42)							
1200 (48)							
1400 (56)							

S-6-1400/2800

DN, mm (")	Maximum test pressure, bar (psi)						
	cl.600		cl.900		cl.1500		cl.2500
400...700 (16...28)	160 (2300)	210 (3000)	275 (4000)	305 (4400)	375 (5400)	520 (7500)	630 (9100)
800 (32)							
900 (36)							
1000 (40)							
1050 (42)							
1200 (48)							
1400 (56)*			#				

Maximum test Pressure can be increased by use of inner Radial seal adapters.



SPECIFICATIONS:

Parameter	S-6-1400/4000	S-6-1400/3200	S-6-1400/2800
Maximum clamping force, t	4000	3200	2800
Distance between test tables (min/max), mm (")	800/3400 (32/134)	800/3400 (32/134)	600/3400 (24/134)
Distance between screw rods, mm (")	2950 (115)		2620 (103)
Overall dimensions (LxWxH), mm (")	8500x4200x3000 (334x165x118)	8000x4000x2900 (315x157x114)	7800x3800x2900 (307x149x114)
Electric power supply, V/Hz	400/50		
Power consumption, kW	40		
Weight, kg	80000	70000	60000

* Maximum diameter for wedge gate valves (except ball valves).

S-6-1200/2000, S-6-500/250, S-6-500/160

TEST BENCHES FOR SHUT OFF & CONTROL VALVES DN 10...1400 mm ($\frac{3}{8}$...56")

S-6-1200/2000

DN, mm (")	Maximum test pressure, bar (psi)								
	cl.150...300	cl.600		cl.900	cl.1500		cl.2500		
	120 (1700)	165 (2400)	200 (2900)	230 (3300)	285 (3700)	360 (5200)	470 (6800)	630 (9100)	650 (9400)
400...500 (16...20)									
600 (24)									
700 (28)									
800 (32)									
900 (36)									
1000 (40)					#				
1050 (42)				#	#				
1200 (48)*									
1400 (56)*									

S-6-500/250

DN, mm (")	Maximum test pressure, bar (psi)							
	cl.150...300	cl.600	cl.900		cl.1500	cl.2500		
	75 (1100)	110 (1600)	165 (2400)	220 (3200)	285 (4100)	410 (6000)	610 (8847)	650 (9400)
50...150 (2...6)								
200 (8)								
250 (10)								
300 (12)								
350 (14)								
400 (16)								
500 (20)								
600 (24)*								

S-6-500/160

DN, mm (")	Maximum test pressure, bar (psi)							
	cl.150...300			cl.600	cl.900		cl.1500	cl.2500
	50 (700)	70 (1000)	110 (1600)	140 (2000)	190 (2700)	275 (4000)	400 (6000)	650 (9400)
10...150 ($\frac{3}{8}$...6)								
200 (8)								
250 (10)								
300 (12)								
350 (14)								
400 (16)			#					
500 (20)								
600 (24)*								

Maximum test Pressure can be increased by use of inner Radial seal adapters.



SPECIFICATIONS:

Parameter	S-6-1200/2000	S-6-500/250	S-6-500/160
Maximum clamping force, t	2000	250	160
Distance between test tables (min/max), mm (")	550/3600 (22/142)	100/1850 (4/33)	79/1457 (3/57)
Distance between screw rods, mm (")	2500 (98)	990 (32)	1004 (40)
Electric power supply, V/Hz		400/50	
Power consumption, kW	25	2	3
Overall dimensions (LxWxH), mm (")	7000x4300x5000 (276x169x197)	3410x1550x1576 (134x61x62)	4080x1445x1632 (160x57x64)
Weight, kg	46000	3300	3436

* Maximum diameter for wedge gate valves (except ball valves).

S-5-1050/1300, S-5-1000/600, S-5-800/750

TEST BENCHES FOR SHUT OFF & CONTROL VALVES DN 100...1400 mm (4...56")

S-5-1050/1300

DN, mm (")	Maximum test pressure, bar (psi)									
	cl.150...300		cl.600		cl.900		cl.1500		cl.2500	
200...400 (8...16)	105 (1500)	130 (1900)	150 (2200)	185 (2700)	235 (3400)	305 (4400)	410 (6000)	580 (8400)	650 (9400)	
500 (20)										#
600 (24)										
700 (28)										
800 (32)										
900 (36)										
1000 (40)				#						
1050 (42)			#	#						
1200 (48)*										

S-5-1000/600

DN, mm (")	Maximum test pressure, bar (psi)											
	cl.150			cl.300			cl.600		cl.900		cl.1500	
100...300 (4...12)	40 (580)	50 (700)	60 (900)	70 (1000)	85 (1200)	110 (1500)	140 (2000)	190 (2800)	265 (3900)	410 (6000)	535 (7800)	650 (9400)
350 (14)												
400 (16)												
500 (20)												
600 (24)												
700 (28)												
800 (32)												
900 (36)												
1000 (40)						#						
1050 (41)*												
1200 (47)*												
1400 (55)*												

S-5-800/750

DN, mm (")	Maximum test pressure, bar (psi)							
	cl.150...300		cl.600		cl.900		cl.1500	
150...350 (6...14)	85 (1200)	105 (1500)	135 (2000)	175 (2500)	235 (3400)	335 (4900)	515 (7500)	650 (9400)
400 (16)								
500 (20)							#	
600 (24)								
700 (28)								
800 (32)				#				
900 (36)*								
1000 (40)*								

Maximum test Pressure can be increased by use of inner Radial seal adapters.

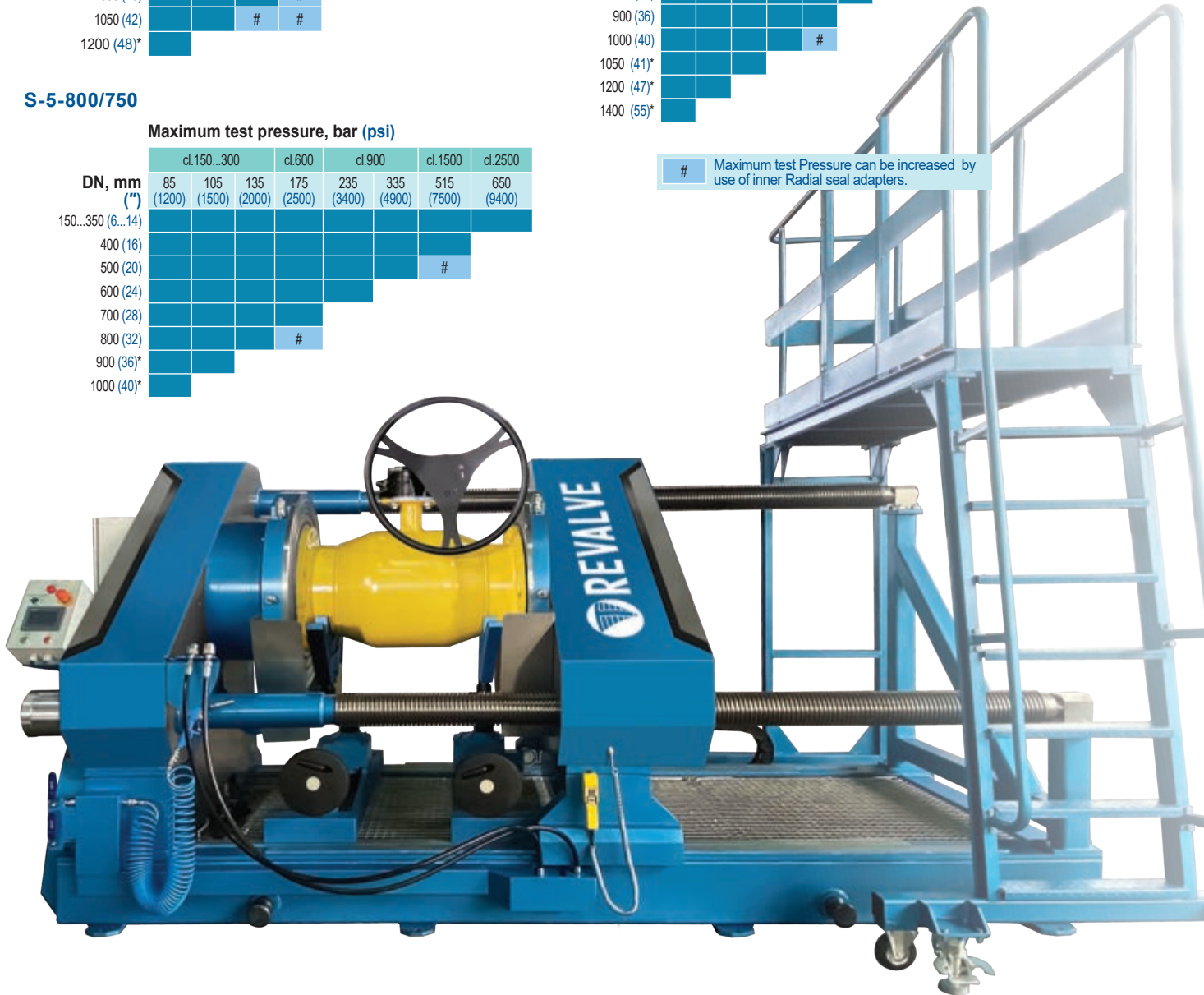

SPECIFICATIONS:

Parameter	S-5-1050/1300	S-5-1000/600	S-5-800/750
Maximum clamping force, t	1300	600	750
Distance between test tables (min/max), mm (")	400/2600 (16/102)	170/2800 (6/110)	220/2300 (8/90)
Distance between screw rods, mm (")	1750 (69)	1675 (66)	1360 (53)
Electric power supply, V/Hz		400/50	
Power consumption, kW		20	
Overall dimensions (LxWxH), mm (")	5600x3140x3035 (220x124x119)	6000x3000x3000 (236x118x118)	6000x3000x2500 (236x118x98)
Weight, kg	29000	10000	15000

* Maximum diameter for wedge gate valves (except ball valves).

S-5-600/500, S-5-600/350, S-5-500/250

TEST BENCHES FOR SHUT OFF & CONTROL VALVES DN 50...800 mm ($\frac{3}{8}$...32")

S-5-600/500

Maximum test pressure, bar (psi)

DN, mm (")	cl.150...300		cl.600		cl.900		cl.1500	cl.2500
	90 (1300)	115 (1700)	155 (2200)	220 (3200)	330 (4800)	435 (6300)	570 (8300)	650 (9400)
50...250 (2...10)								
300 (12)								#
350 (14)								
400 (16)						#		
500 (20)								
600 (24)								
700 (28)*								
800 (32)*								

S-5-600/350

Maximum test pressure, bar (psi)

DN, mm (")	cl.150...300		cl.600	cl.900		cl.1500		cl.2500
	80 (1100)	110 (1500)	150 (2200)	230 (3300)	305 (4400)	400 (5800)	570 (8300)	650 (9400)
50...200 (2...8)								
250 (10)								
300 (12)								
350 (14)								
400 (16)								
500 (20)								
600 (24)								
700 (28)*								

S-5-500/250

Maximum test pressure, bar (psi)

DN, mm (")	cl.150...300		cl.600	cl.900		cl.1500	cl.2500
	75 (1100)	110 (1600)	165 (2400)	220 (3200)	285 (4100)	410 (6000)	650 (9400)
50...150 (2...6)							
200 (8)							
250 (10)							
300 (12)							
350 (14)							
400 (16)							
500 (20)							
600 (24)							

Maximum test Pressure can be increased by use of inner Radial seal adapters.



SPECIFICATIONS:

Parameter	S-5-600/500	S-5-600/350	S-5-500/250
Maximum clamping force, t (lbs)	500	350	250
Distance between test tables (min/max), mm (")		170/2150 (6/85)	100/1300 (4/51)
Distance between screw rods, mm (")	1120 (44)	1090 (43)	816 (32)
Electric power supply, V/Hz		400/50	
Power consumption, kW		3,5	1,8
Overall dimensions (LxWxH), mm (")	3905x1840x1905 (154x72x75)	3900x1800x1865 (154x71x73)	3025x1645x1709 (119x65x67)
Weight, kg	7350	6174	3585

* Maximum diameter for wedge gate valves (except ball valves).

S-5-300/65, S-5-250/60, S-5-150/40

TEST BENCHES FOR SHUT OFF & CONTROL VALVES DN 10...350 mm ($\frac{3}{8}$...14")

S-5-300/65

DN, mm (")	Maximum test pressure, bar (psi)						
	cl.150	cl.300		cl.600	cl.900	cl.1500	cl.2500
63 (900)	80 (1100)	100 (1500)	160 (2300)	250 (3600)	400 (5800)	650 (9400)	
10...100 ($\frac{3}{8}$...4)							
125 (5)							
150 (6)							
200 (8)							
250 (10)							
300 (12)							
350 (14)*							

S-5-250/60

DN, mm (")	Maximum test pressure, bar (psi)					
	cl.300	cl.600	cl.900	cl.1500	cl.2500	
100 (1500)	145 (2100)	250 (3600)	360 (5200)	530 (7600)	650 (9400)	
10...80 ($\frac{3}{8}$...3)						
125 (5)						
150 (6)						
200 (8)						
250 (10)						

S-5-150/40

DN, mm (")	Maximum test pressure, bar (psi)			
	cl.150...600	cl.900	cl.1500	cl.2500
150 (2200)	250 (3600)	420 (6000)	650 (9400)	
10...65 ($\frac{3}{8}$...3)				
80 (3)				
100 (4)				
125, 150 (5, 6)				

Maximum test Pressure can be increased by use of inner Radial seal adapters.



SPECIFICATIONS:

Parameter	S-5-300/65	S-5-250/60	S-5-150/40
Maximum clamping force, t	65	60	40
Distance between test tables (min/max), mm (")	60/900 (2/35)	96/905 (3/35)	40/600 (1/23)
Distance between screw rods, mm (")	525 (20)	503 (19)	337 (13)
Electric power supply, V/Hz		400/50	
Overall dimensions (LxWxH), mm (")	2714x901x1559 (107x35x61)	2410x750x1060 (95x29x42)	2014x692x1610 (79x27x63)
Weight, kg	1675	840	885

* Maximum diameter for wedge gate valves (except ball valves).

S-5P-600/500

TEST BENCHES FOR SUBMERGED TESTING OF SHUT OFF & CONTROL VALVES DN 10...600 mm (3/8"...24")

PURPOSE:

- submerged gas testing of pipeline valves;
- shell test;
- seat tightness test;
- valve stem leak-tightness test (including valve packing).

TESTED VALVES:

- cryogenic valves;
- gate valves;
- ball valves;
- butterfly valves;
- check valves;
- control valves;
- globe valves.

CONFORMS WITH STANDARD:
API 6D; API 598; DIN EN 12266;
DIN 3230; ISO 5208; ASTM E 1003;
GOST 33257, etc.

CONNECTION TYPE:

- flanged (according to ASME B 16.5, ASME B 16.47, GOST 12815 etc.);
- welded ends (according to ASME B 16.25, GOST 16037, etc.);*
- threaded-ends for a small size valves;*
- set of sealing adapters available.*

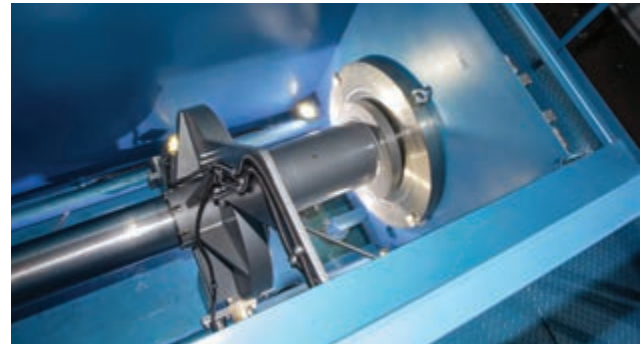

FEATURES:

- Innovative PLC operated proportional clamping control system ensures accurate test results as per API standards. At the initial hydraulic cylinder stroke, pneumatic damper creates low pre-clamping force saving small sized valves bodies from damage. Cylinder actuation proportionally pre-programmed against supplied test pressure, minimizes axial load on valve body, its welding joints and sealing elements throughout the testing process, ensuring long service life of tested valves.*
- Unique design of the stainless steel multi-table adapters with groove installed sealing O-rings allow to test most of the ASME flanged valves (RF and RTJ) with all specified diameters.
- Clamping unit can be provided with radial sealing type or self-sealing adapters.*
- Bidirectional sealing during tests does not require the tested valve rearrangement, which significantly reduces the test time.
- Test bench is equipped with high-performance vacuum system, that serves for removing of air trap in the valve body providing test process safety and precise testing parameters.*
- Test bench is equipped with a stainless steel water-collection tray.
- Test preparation time is significantly reduced by using high-pressure hoses with quick-release couplings.
- Test bench is quickly adjusted to face-to-face dimensions of valve by using the hydraulically or electrically driven cross-head with remote control.
- Patented design of self-sealing adapters exclude axial compression during tests, which ensures test reliability, protects valves against deformation, and extends valves life.*
- All water-wetted parts are corrosion-proof.
- Test bench can be equipped with replaceable sealing adapters for welded ends.*
- Integrated Safety Systems include: safety interlock, overpressure protection, hydraulic oil temperature control, light indication while under pressure, emergency stop button.
- Test bench equipped with valve lifting platforms for valve positioning and support during testing.*

OPTIONAL:



* Upon customer request.

S-5P-600/500

TEST BENCHES FOR SUBMERGED TESTING OF SHUT OFF & CONTROL VALVES
 DN 10...600 mm (3/8"...24")

S-5P-600/500



DN, mm (")	Maximum test pressure, bar (psi)					
	cl.150...600		cl.900		cl.1500	
160 (2300)	230 (3300)	355 (5100)	460 (6600)	615 (8900)	630 (9100)	
10...250 (3/8"...10)						
300 (12)						#
350 (14)						
400 (16)				#		
500 (20)						
600 (24)						

Maximum test Pressure can be increased by use of inner Radial seal adapters.



SPECIFICATIONS:

Parameter	S-5P-600/500
Maximum clamping force, t	500
Distance between test tables (min/max), mm (")	180/1850 (7/73)
Distance between screw rods, mm (")	1300 (51)
Electric power supply, V/Hz	400/50
Power consumption, kW	18
Overall dimensions (LxWxH), mm (")	6720x3580x3270 (264x148x128)
Weight, kg	12300

S-5P-80/6-5

MULTI-STATION TEST BENCH FOR SUBMERGED GAS TESTING OF SHUT OFF VALVES DN 15...80 mm (1/2...3")

PURPOSE:

- submerged gas testing of pipeline valves;
- shell test;
- seat tightness tests;
- valve stem leak-tightness test (including valve packing).

TESTED VALVES:

- cryogenic valves;
- gate valves;
- stop valves (globe valves).

CONNECTION TYPE:

- flanged (according to ASME B 16.5, GOST 12815 etc.);
- welded (according to ASME B 16.25, GOST 16037, etc.).

CONFORMS WITH STANDARD:
*API 6D; API 598; DIN EN 12266;
DIN 3230; ISO 5208; ASTM E 1003;
GOST 33257, etc.*



FEATURES:

- The tank, power rack, piping and all parts of the test bench that are submerged under water are made of stainless steel. The two-sided gate seal tests do not require the tested valve rearrangement, which significantly reduces the test time. Test from one to five valves is executed simultaneously.
- Clamping of tested valves is performed by hydraulic cylinders mounted on each test station, independently of each other.
- The power frame is disposed within the water tank and submerged under water to a depth from 0 to 600 mm (24").
- For easy installation of valves to be tested the power rack rises above the tank.
- For easy inspection of tested valves the tank of the test bench is provided with an internal illumination.
- Test preparation time is significantly reduced by using the high-pressure quick-connect hoses.
- Stainless steel power rack of test bench is actuated by two pneumatic cylinders.

S-5P-80/6-5

MULTI-STATION TEST BENCH FOR SUBMERGED GAS TESTING OF SHUT OFF VALVES DN 15...80 mm (1/2...3")

S-5-80/6-5

DN, mm (")	Maximum test pressure, bar (psi)*					
	d.150...300		d.900		d.1500	d.2500
15...32 (1/2...1 1/4)	95 (1300)	135 (1900)	225 (3200)	330 (4700)	475 (6800)	630 (9100)
40 (1 1/2)					#	
50 (2)						
65 (2 1/2)						
80 (3)						

Maximum test Pressure can be increased by use of inner Radial seal adapters.



SPECIFICATIONS:

Parameter	S-5P-80/6-5
Maximum clamping force of each test station, t	6
Distance between test tables (min/max), mm (")	110/510 (4/18)
Distance between the screws, mm (")	270 (11)
Power supply, V/Hz	400/50
Power consumption, kW	5,5
Overall dimensions (LxWxH), mm (")	2730x1750x1370 (107x69x54)
Weight, kg	2650

* Upon customer request.

VALVE TESTING EQUIPMENT

VERTICAL TEST BENCHES FOR HYDRAULIC AND PNEUMATIC TESTING OF SHUT OFF & CONTROL VALVES

PURPOSE:

Testing of shut-off and control valves:

- shell test acc. to API 598, API 6D, ISO 5208 etc.;
- seat leakage test (cavities A to B, B to A) acc. to API 598, API 6D, ISO 5208 etc.;
- backseat test acc. to API 598, API 6D, ISO 5208 etc.;
- DBB/DIB test acc. to API 598, API 6D;
- control valve seat leakage test, acc. to ANSI FCI 70.2, IEC 60534-4, EN 1349 etc.

CONNECTION TYPE:

- flanged (according to ASME B 16.5, GOST 12815 etc.);
- welded (according to ASME B 16.25, GOST 16037, etc.);
- threaded;*
- union.*

TESTED VALVES:

- gate valves;
- ball valves;
- stop valves (globe valves);
- check valves;
- butterfly gates;
- plug valves;
- control valves.

FEATURES:

- Innovative PLC operated proportional clamping control system ensures accurate test results as per API standards. At the initial hydraulic cylinder stroke, pneumatic damper creates low pre-clamping force saving small sized valves bodies from damage. Cylinder actuation proportionally pre-programmed against supplied test pressure, minimizes axial load on valve body, its welding joints and sealing elements throughout the testing process, ensuring long service life of tested valves.*
- Unique design of the stainless steel multi-table adapters with groove installed sealing O-rings allow to test most of the ASME flanged valves (RF and RTJ) with all specified diameters.
- Clamping unit can be provided with radial sealing type or self-sealing adapters.*
- Bidirectional sealing during tests does not require the tested valve rearrangement, which significantly reduces the test time.
- Test bench is equipped with high-performance vacuum system, that serves for removing of air trap in the valve body providing test process safety and precise testing parameters.*
- Test bench is equipped with a stainless steel water-collection tray.
- Test preparation time is significantly reduced by using high-pressure hoses with quick-release couplings.
- Test bench is quickly adjusted to face-to-face dimensions of valve by using the hydraulically or electrically driven cross-head with remote control.
- Patented design of self-sealing adapters exclude axial compression during tests, which ensures test reliability, protects valves against deformation, and extends valves life.*
- All water-wetted parts are corrosion-proof.
- Test bench can be equipped with replaceable sealing adapters for welded ends.*
- Integrated Safety Systems include: safety interlock, overpressure protection, hydraulic oil temperature control, light indication while under pressure, emergency stop button.
- Turning 180 degrees upper crosshead simplifies the installation of valves prior to testing, and allows visual detection of seat leakage point.
- Test bench equipped with support platforms for valve positioning and support during testing.*
- Fast clamping and centering of tested valve is ensured due to synchronized travel of clamps.

MAXIMUM CLAMPING FORCE CHART(T) :

DN, mm (")	10 (¾)	15 (½)	20 (¾)	25 (1)	32 (1¼)	40 (1½)	50 (2)	65 (2½)	80 (3)	100 (4)	125 (5)	150 (6)	200 (8)	250 (10)	300 (12)	350 (14)	400 (16)	500 (20)	600 (24)	700 (28)	750 (30)	800 (32)
cl.150	15	15	15	15	15	15	15	15	15	15	15	15	15	40	40	40	60	100	100	160	160	160
cl.300	15	15	15	15	15	15	15	15	15	15	15	15	40	60	60	100	160	220				
cl.400	15	15	15	15	15	15	15	15	15	15	40	40	40	60	100	160	160	220				
cl.600	15	15	15	15	15	15	15	15	15	15	40	40	60	100	160	220	220					
cl.900	15	15	15	15	15	15	15	15	15	40	40	60	100	160	220							
cl.1500	15	15	15	15	15	15	40	40	40	60	100	160	220									
cl.2500	15	15	15	15	15	15	40	40	40	100	100	160										

Note: Required tones of clamping force for valve shell test with test pressure 1.5 times exceeding nominal. Parameters are based on face sealing of RF flanged valves.

OPTIONAL:



* Upon customer request.

S-3-800/160, S-3-600/220, S-3-600/160

TEST BENCHES FOR SHUT OFF & CONTROL VALVES DN 10...800 mm ($\frac{3}{8}$...32")

S-3-800/160

Maximum test pressure, bar (psi)

DN, mm (")	-	cl.150		cl.300		cl.600		cl.900	cl.1500	cl.2500
	25 (300)	35 (500)	50 (700)	70 (1000)	110 (1500)	145 (2100)	190 (2800)	270 (4000)	400 (6100)	630 (9100)
10...150 (¾...6)										
200 (8)										
250 (10)										
300 (12)										
350 (14)										
400 (16)										
500 (20)										
600 (24)										
700 (28)										
800 (32)										

S-3-600/220

Maximum test pressure, bar (psi)

DN, mm (")	cl.150...300		cl.600		cl.900	cl.1500		cl.2500	
	70 (1000)	100 (1500)	150 (2200)	200 (2900)	265 (3900)	380 (5500)	580 (8500)	1050 (15000)	1100 (16000)
10...125 (¾...5)									
150 (6)									
200 (8)									
250 (10)									
300 (12)									
350 (14)									
400 (16)									
500 (20)									
600 (24)									

S-3-600/160

Maximum test pressure, bar (psi)

DN, mm (")	cl.150		cl.300		cl.600		cl.900	cl.1500	cl.2500
	50 (700)	70 (1000)	110 (1600)	145 (2100)	190 (2800)	270 (3900)	400 (5800)	630 (9100)	
10...150 (¾...6)									
200 (8)									
250 (10)									
300 (12)									
350 (14)									
400 (16)									
500 (20)									
600 (24)									



SPECIFICATIONS:

Parameter	S-3-800/160	S-3-600/220	S-3-600/160
Maximum clamping force, t	160	220	160
Diameter of the clamped flange (min/max), mm (")	160/1020 (6/40)	160/910 (6/36)	90/840 (3/33)
Maximum thickness of clamped flange, mm (")	90 (3)	115 (4)	90 (3)
Distance between test tables (min/max), mm (")	80/1450 (3/57)	160/1445 (6/57)	90/1255 (4/50)
Distance between the columns, mm (")	1150 (45)	970 (38)	900 (35)
Power supply, V/Hz		400/50	
Power consumption, kW		1,1	
Overall dimensions (LxWxH), mm (")	2055x1740x4370 (81x69x176)	1825x1200x4505 (72x47x177)	1730x1677x3970 (68x66x156)
Weight, kg	4235	4302	3391

S-3-600/100, S-3-500/160, S-3-500/100, S-3-500/60

TEST BENCHES FOR SHUT OFF & CONTROL VALVES DN 10...600 mm (3/8...24")

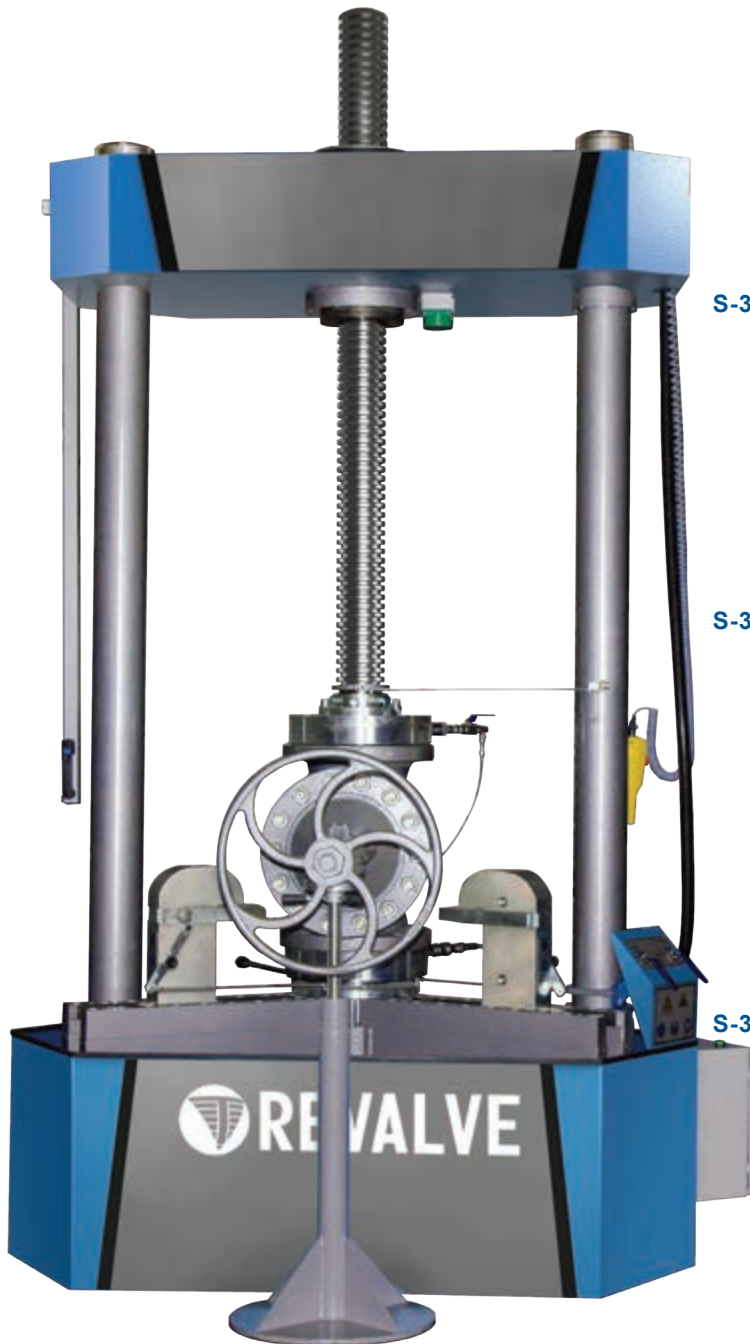

S-3-600/100

DN, mm (")	Maximum test pressure, bar (psi)							
	cl.150		cl.300			cl.600	cl.900	cl.1500
30 (400)	45 (600)	70 (1000)	90 (1300)	120 (1700)	170 (2500)	265 (3800)	450 (6500)	630 (9100)
10...125 (3/8...5)								
150 (6)								
200 (8)								
250 (10)								
300 (12)								
350 (14)								
400 (16)								
500 (20)								
600 (24)								

S-3-500/160

DN, mm (")	Maximum test pressure, bar (psi)						
	cl.150...300		cl.600	cl.900	cl.1500	cl.2500	
70 (1000)	110 (1300)	145 (2100)	190 (2800)	270 (3900)	400 (5800)	630 (9100)	
10...150 (3/8...6)							
200 (8)							
250 (10)							
300 (12)							
350 (14)							
400 (16)							
500 (20)							

S-3-500/100

DN, mm (")	Maximum test pressure, bar (psi)							
	cl.150	cl.300			cl.600	cl.900	cl.1500	cl.2500
45 (600)	70 (1000)	90 (1300)	120 (1700)	170 (2500)	265 (3800)	450 (6500)	630 (9100)	
10...125 (3/8...5)								
150 (6)								
200 (8)								
250 (10)								
300 (12)								
350 (14)								
400 (16)								
500 (20)								

S-3-500/60

DN, mm (")	Maximum test pressure, bar (psi)									
	cl.150			cl.300		cl.600	cl.900	cl.1500	cl.2500	
25 (300)	40 (500)	55 (700)	70 (1000)	100 (1500)	150 (2200)	280 (4000)	400 (5800)	600 (8700)	630 (9100)	
10...80 (3/8...3)										
100 (4)										
125 (5)										
150 (6)										
200 (8)										
250 (10)										
300 (12)										
350 (14)										
400 (16)										
500 (20)										

SPECIFICATIONS:

Parameter	S-3-600/100	S-3-500/160	S-3-500/100	S-3-500/60
Maximum clamping force, t	100	160	100	60
Diameter of the clamped flange (min/max), mm (")	90/840 (3/33)	90/730 (3/28)	90/730 (3/28)	90/730 (3/28)
Maximum thickness of clamped flange, mm (")	115 (4)	90 (3)	115 (4)	
Distance between test tables (min/max), mm (")	72/1252 (3/49)	77/1146 (3/45)	112/1160 (4/45)	70/1000 (3/39)
Distance between the columns, mm (")	900 (35)	750 (29)	770 (30)	775 (31)
Power supply, V/Hz	400/50			
Power consumption, kW	1,1			
Overall dimensions (LxWxH), mm (")	1725x1522x3890 (63x60x153)	1495x1405x3707 (59x55x146)	1495x1400x3646 (59x55x143)	1350x1408x3095 (53x55x122)
Weight, kg	3047	3112	2452	1803

S-3-400/60, S-3-400/40, S-3-300/40, S-3-250/15

TEST BENCHES FOR SHUT OFF & CONTROL VALVES DN 10...400 mm ($\frac{3}{8}$... 16")



S-3-400/60

		Maximum test pressure, bar (psi)								
		cl.150		cl.300		cl.600	cl.900	cl.1500		cl.2500
DN, mm (")		40 (500)	55 (700)	70 (1000)	100 (1500)	150 (2200)	280 (4100)	400 (5800)	600 (8700)	630 (9100)
10...80 ($\frac{3}{8}$...3)										
100 (4)										
125 (5)										
150 (6)										
200 (8)										
250 (10)										
300 (12)										
350 (14)										
400 (16)										

S-3-400/40

		Maximum test pressure, bar (psi)								
		-	cl.150		cl.300		cl.600	cl.900	cl.1500	cl.2500
DN, mm (")		25 (300)	35 (500)	45 (600)	70 (1000)	105 (1500)	190 (2800)	250 (3600)	405 (5900)	630 (9100)
10...80 ($\frac{3}{8}$...3)										
100 (4)										
125 (5)										
150 (6)										
200 (8)										
250 (10)										
300 (12)										
350 (14)										
400 (16)										

S-3-300/40

		Maximum test pressure, bar (psi)						
		cl.150	cl.300		cl.600	cl.900	cl.1500	cl.2500
DN, mm (")		45 (600)	70 (1000)	105 (1500)	190 (2800)	250 (3600)	405 (5900)	630 (9100)
10...80 ($\frac{3}{8}$...3)								
100 (4)								
125 (5)								
150 (6)								
200 (8)								
250 (10)								
300 (12)								

S-3-250/15

		Maximum test pressure, bar (psi)								
		-	cl.150	cl.300		cl.600	cl.900	cl.1500	cl.2500	
DN, mm (")		25 (300)	37.5 (500)	70 (1000)	95 (1400)	150 (2200)	240 (3500)	320 (4600)	540 (7800)	630 (9100)
10...40 ($\frac{3}{8}$...1½)										
50 (2)										
65 (2½)										
80 (3)										
100 (4)										
125 (5)										
150 (6)										
200 (8)										
250 (10)										

SPECIFICATIONS:

Parameter	S-3-400/60	S-3-400/40	S-3-300/40	S-3-250/15
Maximum clamping force, t	60	40		15
Diameter of the clamped flange (min/max), mm (")	90/580 (3/23)		90/460 (3/18)	
Maximum thickness of clamped flange, mm (")	115 (4)			
Distance between test tables (min/max), mm (")	70/1005 (2/40)	78/931 (3/37)	56/871 (2/34)	22/636 (1/25)
Distance between the columns, mm (")	630 (25)	645 (25)	500 (19)	480 (19)
Overall dimensions (LxWxH), mm (")	1210x1313x3055 (48x52x120)	1203x1131x2879 (47x45x113)	981x1038x2690 (39x41x106)	958x1038x2235 (38x41x88)
Weight, kg	1597	1083	860	629

TEST BENCHES WITH SLIDING TABLE

FOR HYDRAULIC AND PNEUMATIC TESTING OF SHUT-OFF VALVES

PURPOSE:

- shell test;
- seat leakage tests;
- backseat test;
- valve stem leak-tightness test;
- pressure safety valves seat tightness test;
- pressure safety valves operation test.

TESTED VALVES:

- gate valves;
- shut-off valves (globe valves);
- check valves;
- butterfly valves;
- ball and plug valves;
- pressure safety valves.

CONNECTION TYPE:

- flanged;*
- welded;*
- nozzle ;*
- coupling;*
- trunnion.*

FEATURES:

- Innovative PLC operated proportional clamping control system ensures accurate test results as per API standards. At the initial hydraulic cylinder stroke, pneumatic damper creates low pre-clamping force saving small sized valves bodies from damage. Cylinder actuation proportionally pre-programmed against supplied test pressure, minimizes axial load on valve body, its welding joints and sealing elements throughout the testing process, ensuring long service life of tested valves.*
- Unique design of the stainless steel multi-table adapters with groove installed sealing O-rings allow to test most of the ASME flanged valves (RF and RTJ) with all specified diameters.
- Clamping unit can be provided with radial sealing type or self-sealing adapters.*
- Bidirectional sealing during tests does not require the tested valve rearrangement, which significantly reduces the test time.
- Test bench is equipped with high-performance vacuum system, that serves for removing of air trap in the valve body providing test process safety and precise testing parameters.*
- Test bench is equipped with a stainless steel water-collection tray.
- Test preparation time is significantly reduced by using high-pressure hoses with quick-release couplings.
- Test bench is quickly adjusted to face-to-face dimensions of valve by using the hydraulically or electrically driven cross-head with remote control.
- Patented design of self-sealing adapters exclude axial compression during tests, which ensures test reliability, protects valves against deformation, and extends valves life.*
- All water-wetted parts are corrosion-proof.
- Test bench can be equipped with replaceable sealing adapters for welded ends.*
- Integrated Safety Systems include: safety interlock, overpressure protection, hydraulic oil temperature control, light indication while under pressure, emergency stop button.
- Fast clamping and centering of tested valve is ensured due to synchronized travel of clamps.
- Rail sliding bottom crosshead simplifies the installation of valves prior to testing, and allows visual detection of seat leakage point.
- Installation and testing process is fully mechanized (provide safe and easy operation with valve positioning before test.)

OPTIONAL:

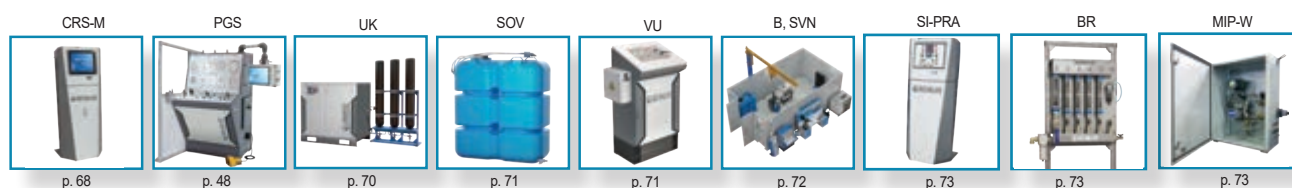

S-3-500/400, S-3-400/400V

TEST BENCHES FOR SHUT OFF & CONTROL VALVES DN 25...500 mm (1 ...20")

S-3-500/400

DN, mm (")	Maximum test pressure, bar (psi)	
	cl.600 150 (2200)	cl.2500 650 (9400)
25...200 (1...8)		
250 (10)		
300 (12)		
400 (16)		
500 (20)		

S-3-400/400V

DN, mm (")	Maximum test pressure, bar (psi)
	cl.900 200 (2900)
25...400 (1...16)	



SPECIFICATIONS:

Parameter	S-3-500/400	S-3-400/400V
Maximum clamping force, t	400	400
Diameter of the clamped flange (min/max), mm (")	110/815 (4/32)	160/730 (6/29)
Maximum thickness of the clamped flange, mm (")	142 (5)	110 (4)
Distance between test tables (min/max), mm (")	100/1300 (4/51)	100/1080 (4/43)
Distance between the columns, mm (")	1260 (50)	970 (38)
Power supply, V/Hz		400/50
Power consumption, kW	5	25
Overall dimensions (LxWxH), mm (")	2460x1800x4820 (97x71x190)	3100x2730x4400 (122x107x173)
Weight, kg	11390	9650

TILTING TEST BENCHES

FOR HYDRAULIC AND PNEUMATIC TESTING OF SHUT OFF & CONTROL VALVES

PURPOSE:

- shell test acc. to API 598, API 6D, ISO 5208 etc.;
- seat leakage test (cavities A to B, B to A) acc. to API 598, API 6D, ISO 5208 etc.;
- backseat test acc. to API 598, API 6D, ISO 5208 etc.;
- DBB/DIB test acc. to API 598, API 6D;
- control valve seat leakage test, acc. to ANSI FCI 70.2, IEC 60534-4, EN 1349 etc.

TESTED VALVES:

- gate valves;
- ball valves;
- globe valves;
- check valves;
- butterfly gates;
- plug valves.

CONNECTION TYPE:

- flanged RF, FF, RTJ (according to ASME B 16.5, ASME 16.47 etc.);
- welded (according to ASME B 16.25, etc.);
- flangeless (lug, wafer type).

FEATURES:

- Innovative PLC operated proportional clamping control system ensures accurate test results as per API standards. At the initial hydraulic cylinder stroke, pneumatic damper creates low pre-clamping force saving small sized valves bodies from damage. Cylinder actuation proportionally pre-programmed against supplied test pressure, minimizes axial load on valve body, its welding joints and sealing elements throughout the testing process, ensuring long service life of tested valves.*
- Unique design of the stainless steel multi-table adapters with groove installed sealing O-rings allow to test most of the ASME flanged valves (RF and RTJ) with all specified diameters.
- Clamping unit can be provided with radial sealing type or self-sealing adapters.*
- Bidirectional sealing during tests does not require the tested valve rearrangement, which significantly reduces the test time.
- Test bench is equipped with high-performance vacuum system, that serves for removing of air trap in the valve body providing test process safety and precise testing parameters.*
- Test bench is equipped with a stainless steel water-collection tray.
- Test preparation time is significantly reduced by using high-pressure hoses with quick-release couplings.
- Test bench is quickly adjusted to face-to-face dimensions of valve by using the hydraulically or electrically driven cross-head with remote control.
- Patented design of self-sealing adapters exclude axial compression during tests, which ensures test reliability, protects valves against deformation, and extends valves life.*
- All water-wetted parts are corrosion-proof.
- Test bench can be equipped with replaceable sealing adapters for welded ends.*
- Integrated Safety Systems include: safety interlock, overpressure protection, hydraulic oil temperature control, light indication while under pressure, emergency stop button.
- Test bench equipped with valve lifting platforms for valve positioning and support during testing.*
- Fast clamping and centering of tested valve is ensured due to synchronized travel of clamps.
- Test bench allows visual detection of seat leakage point.
- Installation and testing process is fully mechanized (provide safe and easy operation with valve positioning before test).
- Possibility to observe sealing surface during leakage test (under 45 degrees).
- No air traps during filling, the valve is filled vertically and then tilted to horizontal position.

OPTIONAL:



S-4-400/270, S-4-400/180, S-4-300/40

TEST BENCHES FOR SHUT OFF & CONTROL VALVES DN 15...400 mm (1/2...16")

S-4-400/270

		Maximum test pressure, bar (psi)			
		cl.150...600	cl.900	cl.1500	cl.2500
DN, mm (")		190 (2700)	245 (3500)	330 (4700)	485 (7000)
50...200 (2...8)					
250 (10)					
300 (12)				#	
350 (14)					
400 (16)					

S-4-400/180

		Maximum test pressure, bar (psi)				
		cl.600	cl.600	cl.900	cl.1500	cl.2500
DN, mm (")		120 (1700)	155 (2200)	200 (2900)	275 (3900)	450 (6500)
10...200 (1/2...8)						
250 (10)						
300 (12)						
350 (14)						
400 (16)						

S-4-300/40

		Maximum test pressure, bar (psi)					
		cl.150	cl.300	cl.600	cl.900	cl.1500	cl.2500
DN, mm (")		45 (600)	70 (1000)	105 (1500)	190 (2800)	250 (4100)	405 (5900)
10...80 (1/2...3)							
100 (4)							
125 (5)							
150 (6)					#		
200 (8)							
250 (10)							
300 (12)							

Maximum test Pressure can be increased by use of inner Radial seal adapters.



SPECIFICATIONS:

Parameter	S-4-400/270	S-4-400/180	S-4-300/40
Maximum clamping force, t	270	180	40
Diameter of the clamped flange (min/max), mm (")	160/670 (6/26)	90/720 (3/28)	160/460 (6/18)
Maximum thickness of the clamped flange, mm (")	110 (4)	94 (4)	55 (2)
Distance between test tables (min/max), mm (")	180/800 (7/31)	75/1420 (2/56)	100/830 (4/33)
Distance between the columns, mm (")	1115 (44)	800 (31)	876 (34)
Power supply, V/Hz		400/50	
Power consumption, kW	5,5	17	5,5
Overall dimensions (LxWxH), mm (")	2000x2060x3370 (79x81x132)	4705x2262x4750 (185x89x187)	1980x1320x2850 (78x52x112)
Weight, kg	5500	7950	1705

PURPOSE:

- pressure source and process control unit for hydraulic and pneumatic tests;
- serves as test bench control panel;
- serves as independent pressure source.



PGS-A

Pressure up to 2500 bar (36250 psi)

FUNCTIONS:

1. Hydraulic test medium pressure up to 2500 bar (36250 psi).
2. Continuous (stepless) pressure control for:
 - hydraulic tests 10...2500 bar (145...36250 psi);
 - pneumatic tests 0,5...400 bar (7...5800 psi).*
3. Smooth control of the test-bench hydraulic clamping cylinder.
4. Automatic maintaining of achieved test pressure.
5. Control of the test process by the pressure-gage panel with the measurement accuracy of 1.0 % (0.6% if requested by customer).
6. PGS is equipped with quick-release couplings to connect additional calibration test gages with the required accuracy (see A).
7. PGS, can be connected to CRS-M for test data recording.
8. Control station can be equipped with durable polycarbonate glass protective screen.

OPTIONS:

- **PGS-P** edition is equipped with the automatic proportional clamping control system. PLC controlled system allows to perform testing of valves in a safe mode excluding axial compression applied to the valve body during testing using automated proportional clamping pressure adjustment in hydraulic cylinder, relatively to testing pressure.
- **PGS-M** is a mobile version of control station, that allows to perform testing at sites (blind flanges are not included).
- **PGS-A** edition allows to perform testing of valves in automatic mode. Also can be provided with proportional clamping control system. The range of process automation should be negotiated and stated in technical specification to the contract at the order stage.
- **PGS-R** edition has module construction and divided into two cabinets.
 - remote control panel separated from components under pressure during testing, ensuring operator safety.
 - high-pressure unit (HPU) with integrated high-pressure pumps and remotely controlled components along with clamping system located inside safety fence (optional) isolating test pressure loaded equipment.

PGS CONTROL STATIONS

COMPLETE SET:

- pressure source unit with the bench control panel:
 - 1 or 2 pneumohydraulic booster pumps (according to model);
 - monitoring, adjustment, and control equipment.
- air preparation unit;
- preliminary and fine water filters;
- pedal for the valve-clipping control during testing (see C);
- air and water leakage control unit;
- set of high-pressure with quick-release couplings;
- set of spare parts, tools, and accessories;
- safety screen (see B);
- integrated computer registration system CRS-M (see D).



PGS-M



PGS-P

FEATURES:

- PGS control circuit uses pneumatically controlled gate elements. This releases the operator from opening and closing numerous needle valves and makes the unit control process simple and reliable.
- Equipment has separate filling line to reduce test preparation time.
- For convenience, control of hydraulic clamping cylinder of test bench can be performed from the control panel and remote pedal (see C).
- PGS external connection diagram uses fast coupling joints with warranted operation life of 10,000 cycles, which significantly reduces the time required to complete preparation and final operations.
- Compressed-air supply line has air-preparation unit and ensures class 0 air supply even when the pneumatic network contains polluted air.
- To extend the unit service life, test water inlet line equipped with a fine water filter.
- pneumatic network contains polluted air.
- To extend the unit operation time, the PGS water input is equipped with a fine water filter.

MULTI-STATION TEST BENCHES

FOR HYDRAULIC AND PNEUMATIC TESTING FOR SHUT OFF & CONTROL VALVES

PURPOSE:

- shell test acc. to API 598, API 6D, ISO 5208 etc.;
- seat leakage test (cavities A to B, B to A) acc. to API 598, API 6D, ISO 5208 etc.;
- backseat test acc. to API 598, API 6D, ISO 5208 etc.;
- DBB/DIB test acc. to API 598, API 6D;
- control valve seat leakage test, acc. to ANSI FCI 70.2, IEC 60534-4, EN 1349 etc.

TESTED VALVES:

- gate valves;
- globe valves;
- check valves;
- butterfly gates;
- ball and plug valves.

CONFORMS WITH STANDARD:
API 6D; API 598; DIN EN 12266;
DIN 3230; ISO 5208; ASTM E 1003;
GOST 33257, etc.

CONNECTION TYPE:

- flanged (according to ASME B 16.5, GOST 12815, etc.);
- welded (according to ASME B 16.25, GOST16037, etc.).

FEATURES:

- Increased productivity due to simultaneous testing of multiple identical valves.
- Testing in semi-automatic and automatic modes which affects the testing quality.
- Digital flowmeters allow to check the leakage rate of valve on each station and each cavity.
- Axial load is minimized by using of self-sealing test tables.
- All the wetted parts are made of stainless steel.
- Two-side leakage test (A to B, B to A) without valve reinstallation (optional feature).
- DBB/DIB tests are available for each station (optional feature).
- Valve actuators are controlled remotely (optional feature).
- Computer registration system allows to create test reports for each station (optional feature).
- Safety screen to improve operator safety (optional feature).
- Remote video control (optional feature).

MAXIMUM CLAMPING FORCE CHART(T) :

DN, mm class	10 (¾)	15 (½)	20 (¾)	25 (1½)	32 (1¼)	40 (1½)	50 (2)	65 (2½)	80 (3)	100 (4)	125 (5)	150 (6)	200 (8)	250 (10)	300 (12)
cl. 150	10	10	10	10	10	10	10	10	10	10	25	25	60	60	100
	10	10	10	10	10	10	10	10	10	10	25	25	60	60	100
	10	10	10	10	10	10	10	10	10	10	25	25	60	60	100
	10	10	10	10	10	10	10	10	10	10	25	25	60	60	100
cl. 300	10	10	10	10	10	10	10	10	10	10	25	25	60	60	10
cl. 400	10	10	10	10	10	10	10	10	10	10	25	25	60	60	100
cl. 600	10	10	10	10	10	10	10	10	10	25	25	60	60	100	160
cl. 900	10	10	10	10	10	10	10	10	25	25	60	60	100	160	
cl. 1500	10	10	10	10	10	10	25	25	60	60	60	100	160		
cl. 2500	10	10	10	10	10	25	25	60	60	100	160	160			

Note: Required tones of clamping force for valve shell test with test pressure 1.5 times exceeding nominal. Parameters are based on face sealing of RF flanged valves.

OPTIONAL:



* Upon customer request.

S-3-300/160-3...S-3-100/60-5

MULTI-STATION TEST BENCH FOR SHUT OFF & CONTROL VALVES DN 10...300 mm (3/8...12")



S-3-300/160-3

SPECIFICATIONS:

Parameter	S-3-100/10-3	S-3-150/30-3	S-3-200/60-3	S-3-250/100-3	S-3-300/160-3	S-3-100/10-5	S-3-150/30-5	S-3-100/60-5
Number of posts			3				5	
Maximal clamping force, t	3x30	3x25	3x62	3x104	3x160	5x12	5x30	5x62
Min./max. diameter of the clamped flange, mm (")	100 (4)	150 (6)	100 (4)	250 (10)	300 (12)	100 (4)	150 (6)	100 (4)
Max. construction reinforcement length, mm (")	450 (18)	600 (24)	750 (30)	800 (32)	1000 (40)	450 (18)	600 (24)	750 (30)
Distance between the columns, mm (")	-	400 (16)	500 (20)	580 (22)	650 (25)	-	400 (16)	500 (20)
Distance between axes of adjacent posts, mm (")	350 (14)	-	-	-	-	350 (14)	-	-
Power supply, V/Hz					400/50			
Power consumption, kW					7,5			
Valve opening/closing control	manually / upon request – automatic valve control with mechanical, pneumatic or electric drive							
Max. test pressure, bar (psi)					650 (9400)	(can be increased upon request)		

TEST BENCHES

FOR TESTING AND CALIBRATION OF PRESSURE SAFETY/RELIEF AND VACUUM (BREATHER) VALVES

PURPOSE:

Test benches are designed for hydraulic and pneumatic testing of spring loaded, pilot-operated safety and relief valves with DN 10...400 mm ($\frac{3}{8}$...16"), according to the following standards:

- set pressure test according to API 526;
- seat tightness test according to API 527.

Advanced test system design, provides correspondence of the PSV test process to requirements of the following standards:

- API RP 576;
- API 526, 527;
- ISO 4126-1;
- ASME BPVC Section VIII;
- ASME PTC 25.

TESTED VALVES TYPES:

- spring loaded PSVs;
- pilot-operated PSVs.

TESTED VALVE SIZES:

- DN 15...400 mm ($\frac{1}{2}$...16") flanged PSVs;
- DN 10...50 mm ($\frac{3}{8}$...2") threaded PSVs.



CLAMPING UNIT

FEATURES:

- Clamping system design is based on integrated high performance hydraulic cylinder, stainless steel base that serves as storage tank for liquid test medium. Clamping of tested valve is provided by test table actuated by hydraulic cylinder and three synchronized claws centering and fastening of inlet PSV flange.
- Increased inner diameter of test system tubing and high pressure hoses provides dynamic spool lifting during set pressure test, as well as smooth and accurate reseating, same time serves to avoid the seats surface damages while closing.
- Use of special Nickel and Chrome coatings and stainless steel elements of clamping unit water wetted surfaces provides stable operation in hard environmental conditions with high level of humidity.
- Built-in stainless steel test fluid storage tank .
- Adapters for PSV inlet flange face sealing for valves with DN 15...400 mm ($\frac{1}{2}$... 12") of the following types: FF, SG, RF, LM, LG, RTJ as per ASME B 16.5.
- Plugs for PSV outlet flange for seat leakage testing with quick connection for drop/bubble counters.

OPTIONS:

- Set of adapters with standard RTJ gasket for inlet flange sealing, designed according to ASME B 16.5.
- Sealing adapters for PSV with male/female threaded connection NPT $\frac{1}{4}$... 2 $\frac{1}{2}$.
- Safety fence to ensure operator safety in accordance with HSE requirements available in several editions:
 - surrounding (two sheets metal blocks) safety fence with bullet proof windows, gates safety locking device and remote operated video control system;
 - safety screen at control station for operator protection from splashes;
 - safety fence arrangement mounted around clamping unit.
- Portable muffler provides noise level reduction at PSVs outlet during pop testing.
- Test unit elements can be positioned on the mobile platform with forklift pockets for easier unit transportation to end-user sites.

MAXIMUM CLAMPING FORCE CHART(T) :

DN, MM (")	10 ($\frac{3}{8}$)	15 ($\frac{1}{2}$)	40 (1 $\frac{1}{2}$)	50 (2)	80 (3)	100 (4)	150 (6)	200 (8)	250 (10)	300 (12)	400 (16)
cl.150	15	15	15	15	15	15	15	15	15	40	40
cl.300	15	15	15	15	15	15	15	15	40	40	
cl.600	15	15	15	15	15	15	40	40	60		
cl.900	15	15	15	15	15	40	40	60			
cl.1500	15	15	15	15	40	40	60				
cl.2500	15	15	15	40	40	60					

Note: Required tones of clamping force for valve shell test with test pressure 1.5 times exceeding nominal. Parameters are based on face sealing of RF flanged valves.

S-1-400/60, S-1-400/40, S-1-300/40

TEST BENCH FOR SAFETY VALVES DN 10...400 mm ($\frac{3}{8}$...16")

S-1-400/40

DN, mm (")	Maximum test pressure, bar (psi)								
	cl.150			cl.300		cl.600	cl.900	cl.1500	cl.2500
	25 (400)	35 (500)	45 (700)	70 (1000)	105 (1500)	190 (2800)	250 (3600)	405 (5900)	630 (9100)
10...80 ($\frac{3}{8}$...3)									
100 (4)									
125 (5)									
150 (6)									
200 (8)									
250 (10)									
300 (12)									
350 (14)									
400 (16)									

S-1-300/40

DN, mm (")	Maximum test pressure, bar (psi)						
	cl.150	cl.300		cl.600	cl.900	cl.1500	cl.2500
	45 (700)	70 (1000)	105 (1500)	190 (2800)	250 (3600)	405 (5900)	630 (9100)
10...80 ($\frac{3}{8}$...3)							
100 (4)							
125 (5)							
150 (6)							
200 (8)							
250 (10)							
300 (12)							



S-1-400/40



S-1-300/40

PSV test unit can be based on a several types of clamping systems, which clamping force and performance capabilities will be calculated according to PSV type, diameter and required pressure rating.

SPECIFICATIONS:

Parameter	S-1-400/60	S-1-400/40		S-1-300/40
	3 claws	3 claws	2 claws	3 claws
Maximum clamping force, t	60		40	
Tested valve sizes, mm (")		10...400 ($\frac{3}{8}$...16)		10...300 ($\frac{3}{8}$...12)
Diameter of the clamped flange (min/max), mm (")	90/580 (4/23)		90/610 (4/24)	90/460 (4/18)
Maximum thickness of the clamped flange, mm (")			115 (4)	
Overall dimensions (LxWxH), mm (")	1175x1313x1006 (46x51x40)	1180x1131x990 (46x45x39)	1170x985x965 (46x39x38)	920x1038x925 (36x41x36)
Weight, kg	944	607	537	466

S-1-250/15, S-1R-250/15

TEST BENCH FOR SAFETY VALVES DN 10...250 mm ($\frac{3}{8}$...10")

S-1-250/15

DN, mm (")	Maximum test pressure, bar (psi)											
	cl.150		cl.300		cl.600		cl.900		cl.1500		cl.2500	
10..40 ($\frac{3}{8}$..2)	25 (400)	35 (500)	70 (1000)	95 (1400)	150 (2100)	240 (3500)	320 (4600)	540 (7800)	630 (9100)			
50 (2)												
65 (3)												
80 (3)												
100 (4)												
125 (5)												
150 (6)												
200 (8)												
250 (10)												

S-1R-250/15

DN, mm (")	Maximum test pressure, bar (psi)						
	cl.150		cl.300			cl.900	
10..65 ($\frac{3}{8}$..2)	24 (300)	35 (500)	65 (900)	100 (1400)	125 (1700)	200 (2800)	250 (3600)
80 (3)							
100 (4)							
125 (5)							
150 (6)							
200 (8)							
250 (10)							



S-1-250/15



S-1R-250/15

FEATURES:

- Mobile test bench S-1R-250/15 can be installed and connected in any place where it is necessary to carry out tests that meet the operating conditions and have the possibility of media supply to the test bench according to the specified characteristics.

SPECIFICATIONS:

Parameter	S-1-250/15	S-1R-250/15
	Maximum clamping force, t	3 claws 15
Tested valve sizes, mm (")	10...250 ($\frac{3}{8}$...10)	
Diameter of the clamped flange (min/max), mm (")	90/460 (4/18)	90/405 (4/16)
Maximum thickness of the clamped flange, mm (")	115 (4)	48 (2)
Overall dimensions (LxWxH), mm (")	915x1038x925 (36x41x36)	1533x713x840 (60x28x33)
Weight, kg	369	410

TEST BENCHES

FOR TESTING AND CALIBRATION OF PRESSURE SAFETY/RELIEF AND VACUUM (BREATHER) VALVES

CONTROL STATION

CONTROL STATION HAS MODULE CONSTRUCTION AND CAN BE EQUIPPED WITH THE FOLLOWING SYSTEMS ACCORDING TO THE CUSTOMER REQUIREMENTS:

- **High pressure hydraulic clamping control system.**
Mandatory system providing comfortable and quick operation of the clamping unit.
- **Pneumatic test system up to 400 bar (5800 psi).**
Test system allows to test the most PSVs (according to API 526/527, up to class 1500) with gas/nitrogen test mediums. System operation requires external compressed air/nitrogen source with maximum pressure up to 400 bar (5800 psi). Compressor unit or booster with accumulators available as an option.
- **Hydraulic and pneumatic test system up to 400 bar (5800 psi).**
Test system allows to test the most PSVs (according to API 526/527, up to class 1500) with liquid or gas/nitrogen test mediums. System operation requires external compressed air/nitrogen source with maximum pressure up to 400 bar (5800 psi). Compressor unit or booster with accumulators available as an option.
- **Pneumatic test system up to 690 bar (10000 psi).**
Optional system based on pneumatic-actuated booster. Used for gas testing of PSVs up to class 2500 and higher. Operation requires external compressed air/gas source with pressure up to 35 bar (500 psi).
- **Hydraulic test system up to 690 bar (10000 psi).**
Optional system used for hydraulic testing of PSVs up to class 2500 and higher. Based on pneumatic-actuated booster. Operation requires external compressed air/gas source with pressure up to 35 bar (500 psi).
- **Pneumatic and Hydraulic test system up to 690 bar (10000 psi).**
Optional system required for high pressure PSVs testing with gas and liquid mediums. Combines both above-mentioned test systems up to 690 bar (10000 psi).



FEATURES:

- Clamping control system is equipped with safety interlock that prevents tested valve unclamping while being under pressure higher than 1 bar.
- Test process is controlled by needle, regulating and isolation valves of world A-class manufacturers.
- Test systems up to 400 bar (5800 psi) are equipped with additional test vessels for increasing of test line volume. Additional test medium volume provides dynamic spool lifting and precise determination of PSVs set point, test line residual pressure, helps in accurate reseating point determination, saving PSVs sealing surfaces from damages while reseating.
- Equipment complies with following standards: ISO 4126-1, API RP 576, ASME BPVC Section VIII, establishing the requirements for the accuracy of the safety valve setting, and the ASME PTC 25 standard, which regulates the speed of the pressure gaining when 90% of the set pressure is reached.
- Systems are equipped with additional lower pressure range gauges for more accurate test parameters measuring at low pressure testing. These pressure gauges are equipped with automatic shut-off devices to avoid pressure gauge damages while test pressure exceeds maximum stated test parameters.
- To improve safety and avoid the risk of uncontrolled increasing of the test pressure, control panel is equipped with a duplicate test line control button, to raise test pressure the operator shall hold the button pressed (two-handed control system)
- Test medium, gas or liquid, can be selected by using switch at the control panel.
- Control panel is equipped with emergency stop button.
- Control stations with hydraulic test systems are equipped with pneumatically driven pump for quick water filling of tested valve.
- Control station can be equipped with durable polycarbonate glass protective screen.
- Test mediums go through fine filters, all water wetted parts are made of corrosion proof materials improving long service life of the test system.

MP-SRV-40

TEST BENCH FOR SAFETY VALVES DN 10...300 mm ($\frac{3}{8}$...12")

PURPOSE:

- Mobile Safety Relief Valve Testing bench is designed for hydraulic and pneumatic testing of Pressure Safety/Relief Valves (spring-loaded and pilot operated) with pressure up to 350 Bar and 40 tons hydraulic clamping force.

TESTED VALVES:

- spring loaded SRVs;
- pilot-operated SRVs.

Advanced test system design, provides correspondence of the SRV test process to requirements of the following international standards:

- Set pressure testing and adjusting of SRVs according to API 526 and ISO 4126-1;
- Seat tightness test of SRVs according to API 527;

Due to modern engineering solutions our equipment meets the requirements of the following standards:

- API RP 576;
- ASME BPVC Section VIII;
- ASME PTC 25.

TYPES OF TESTED VALVES:

Pressure Safety/Relief Valves (spring-loaded and pilot operated) 15...300 mm ($\frac{1}{2}$...12") with RF/RTJ connection (as per ASME B16.5) and NPT connections.

- DN 10...300 mm ($\frac{3}{8}$...12") flanged SRVs;
- DN 10...50 mm ($\frac{3}{8}$...2") threaded SRVs.



MP-SRV-40

TEST BENCH FOR SAFETY VALVES DN 10...300 mm ($\frac{3}{8}$...12")

FEATURES:

- Clamping system design is based on integrated high performance hydraulic cylinder, stainless steel base that serves as storage tank for hydraulic test medium. Clamping of valve to be tested is provided by test table actuated by hydraulic cylinder and three synchronized claws that center and fasten the inlet SRV flange.
- Emergency stop button. In case of emergency by pressing the red button pressure supply stops immediately protecting the operator, personnel and the tested valve. Tested valve stays clamped, test pressure is released.
- Safety interlock system. Unclamping automatically becomes impossible when test pressure in clamping station is above 3 Bar and yellow warning lamp indicates the presence of test pressure.
- Two-hand safety operation. To exclude the risk of uncontrolled pressure increase during pneumatic, hydraulic testing and ensure the safety operation station is equipped with a safety button.
- Light signalization. Light signal on the control station automatically indicates that the valve is under pressure and system is deactivated respectively when the pressure is below 3 bar.
- Increased inner diameter of test system tubing and high-pressure hoses provides dynamic spool lifting during set pressure test, as well as smooth and accurate reseating simultaneously avoiding seats surface damage while closing.

OPTIONS:

- Set of adapters with standard RTJ gasket for inlet flange sealing, designed according to ASME B 16.5.
- Sealing adapters for thread-type SRV sealing NPT $\frac{1}{2}$... 2".
- Safety fence for provision of operator safety in accordance with HSE requirements available in several editions:
 - surrounding (two sheets metal blocks) safety fence with bullet proof windows, gates safety locking device and remote operated video control system;
 - safety screen at control station for operator protection from splashes;
 - strong and robust 4-side safety screen made of protective transparent 12 mm thick Lexan (polycarbonate) on a rigid metal base surrounding the clamping unit.
- Portable muffler provides noise level reduction at SRVs outlet during pop testing.
- Test unit elements can be positioned on the mobile platform with forklift pockets for easier unit transportation to the end user sites.

MP-SRV-40

DN, mm (")	Maximum test pressure, bar (psi)				
	cl.150	cl.300	cl.600	cl.900	cl.1500
45 (600)	70 (1000)	105 (1500)	190 (2800)	350 (5100)	
10...100 ($\frac{3}{8}$...4)					
150 (6)					
200 (8)					
250 (10)					
300 (12)					

- Use of special Nickel and Chrome coatings and stainless steel elements of clamping unit water wetted surfaces provides stable operation in harsh environmental conditions with high level of humidity.
- «Pockets» for set of sealing adapters storage.
- Built-in stainless steel test fluid storage tank.
- Adapters for SRV inlet flange face sealing for valves with DN 15...400 mm ($\frac{1}{2}$...12") of the following types: FF, SG, RF, LM, LG, RTJ as per ASME B 16.5.
- Plugs for SRV outlet flange face sealing with fittings for quick connection of drop/bubble counter tubing.

- REVALVE can optionally provide the clamping unit with two claws that are able to perform testing most of SRV types.
- Computer Registration System is built into the control station for easy process operation and test monitoring. Designed for continuous test data measuring and storing final reports as well as printing test protocols at workshop printer via Wi-Fi quick connection. Software package is customized and operator friendly so doesn't require special skills to launch and run the system. The package can be translated into the required native language upon request.
- Compressor unit. Serves for constant supply of high-pressure air for valve testing. The compressor unit consists of piston-type compressor placed into the acoustic rigid cabinet and mounted on the base. Pressure transmitter, pressure gauge and control panel are on the frame for operator use. Storage cylinder area consists of 3 carbon steel rigid cylinders made of carbon steel fixed on the welded rack.

SPECIFICATIONS:

Parameter	MP-SRV-40
Maximum clamping force, t	40
Tested valve sizes, mm (")	10...300 ($\frac{3}{8}$...12)
Min./max. diameter of the clamped flange, mm (")	90/460 (4/18)
Maximum thickness of the clamped flange, mm (")	125 (5)
Overall dimensions (LxWxH), mm (")	1050x1070x930 (41x42x36)
Weight, kg	485

TEST BENCHES

FOR TESTING AND CALIBRATION OF PRESSURE SAFETY/RELIEF AND VACUUM (BREATHER) VALVES

OPTIONS:

- High pressure booster based gas test system with gas accumulators.
- High pressure compressor unit (air up to 400 bar (5800 psi) with compressed air accumulators up to 150 liters.
- Compressed air saving system. Especially required when customer needs to test a large number of valves within short time period without recharging vessels or compressed air accumulators.
- Computer Registration System.
- CRS-M-based Semi-Automatic Test System.
- Device for breather (pressure vacuum relief) valves testing. Designed for mounting of pressure safety and breather valves DN 50...500 mm (2...20"). Control panel provides testing with overpressure up to 2 bar and vacuum depth of up to 500 mm (20") of water column scale.
- Pressure safety and breather valves testing control system can be either integrated into the general control panel of PSV test system or be made in a separate cabinet, as per client request.
- Upon customers demand test system can be customized to meet specific test parameters.



OPTIONAL:



S-1-600/10

BREATHER VALVES TESTING UNIT WITHIN THE RANGE OF DN 50...600 mm (2...24")

PURPOSE:

- unit is designed for quick and convenient testing of breather valves 50...600 mm (2...24") with vacuum up to 0,8 bar and exceeding air pressure up to 6 bar.

TESTED VALVES:

- breather valves DN 50...600 mm (2...24");
- emergency PSVs with DN 50...600 mm (2...24").

CONNECTION TYPE:

- flanged.

S-1-600/10

DN, mm (")	Maximum test pressure, bar (psi)			
	0,8 (12)	3 (44)	4,5 (65)	6 (87)
50...400 (2...16)				
500 (20)				
600 (24)				

TESTING STANDARDS:

The valves are tested according to API 2000:

- set vacuum test;
- set pressure test;
- seat leakage in vacuum conditions;
- seat leakage in exceeding pressure conditions.

TEST OPERATION CONTROL:

- clamping – manually;
- vacuum and air pressure testing – from control station panel.



FEATURES:

- Air reservoir under the tested valve which is obligatory according to API 2000.
- Volume under the valve allows to pressurize smoothly without pressure hammering.
- Accurate set pressure definition both on vacuum and exceeding pressure.
- Unique technology for defining the valve leakage on vacuum.
- Precise leakage definition in exceeding pressure conditions.
- High-accuracy U-shape manometer used for small pressure values.
- Computerized registration system allows to create test reports (optional feature).

SPECIFICATIONS:

Parameter	S-1-600/10
	4 claws
Maximum clamping force, t	10
Max. diameter of the clamped flange, mm (")	780 (31)
Maximum thickness of the clamped flange, mm (")	30 (1)
Electric power supply, V/Hz	230/50
Power consumption, kW	0,6
Overall dimensions (LxWxH), mm (")	1760x1250x2200 (69x49x87)
Weight, kg	370

SI-25M

UNIT FOR SAFETY VALVES SPRINGS TESTING Ø 25...300 mm (1...12")

PURPOSE:

- testing of the PSVs springs with preset load and measuring of the spring deformation;
- testing of the PSVs springs with preset deformation and measuring of the load required for it;
- checking the spring permanent deformation;
- test report forming.

TESTED ITEMS:

- springs Ø 25...300 mm (1...12").



FEATURES:

- Computer-aided automated control system with touch screen display.
- Tests of all main standard sizes of springs used in safety valves.
- Ready-to-use skid.
- Recording, archiving, and printing-out test protocols.
- No human factor influence on the test results.
- Can be integrated into the company local network.

SPECIFICATIONS:

Parameter	SI-25M
External diameter of springs, mm (")	25...300 (1...12)
Free height of springs, mm (")	50...500 (2...20)
Controlled-load range, kg	5...10000
Power supply, V/Hz	400/50
Motor power, kW	3,5
Overall dimensions (LxWxH), mm (")	1580x1050x2120 (62x41x83)
The weight of the bench and the control panel, kg	1220

D-14-EX

PORTABLE MEASURING SYSTEMS

PURPOSE:

- testing of all types of spring operated Pressure Safety Valves in their operational pipeline position without plant shut-down.



MACHINE CONFIGURATION CHART:

- test rig;
- electronic control box;
- industrial computer;
- pressure sensors;
- force sensors;
- acoustic sensor;
- extension cables;
- accessory kit.

TESTED VALVES:

- spring-loaded safety valves with manual opening mechanism.

LISTED IN THE REGISTER OF APPROVED TYPE MEASURING INSTRUMENTS OF RUSSIAN FEDERATION



FEATURES:

- Allows testing of spring operated safety valves directly on their operational pipeline position without plant shut-down.
- High accuracy of test results due to use of four interchangeable pressure sensors with accuracy class of 0.25% (with ranges of 16, 40, 100, 250, 400 and 600 Bar) as well as three interchangeable force sensors with class of accuracy 0.03% (with ranges of 2; 20; 50 kN).
- Small device weight makes it convenient to move across the plant.
- Does not require connection to any external sources of energy during testing.
- Universal mounting bracket simplifies the device installation.
- Allows testing of Pressure Safety Valves on the pipeline under pressure and without it.
- ATEX certificate allows to use it in hazardous areas.
- Acoustic sensor allows to determine set point precisely
- Emergency valve closing system.
- Availability of vast PSVs database (over 6000 items).

SPECIFICATIONS:

Parameter	D-14-EX
Spool traveling mechanism actuator	hydraulic
Maximum force applied to the PSV spring, kN	2,0; 20,0; 50,0
ATEX certificate	zone 0 and zone 1
Operating temperature, °C	-10...+50
Overall dimensions (LxWxH), mm (*):	
- spool traveling mechanism/ control unit;	230x210x560 (23x7x8) / 700x385x360 (9x8x22)
Weight (spool travelling mechanism / control unit), kg	68,4 (14 / 25)

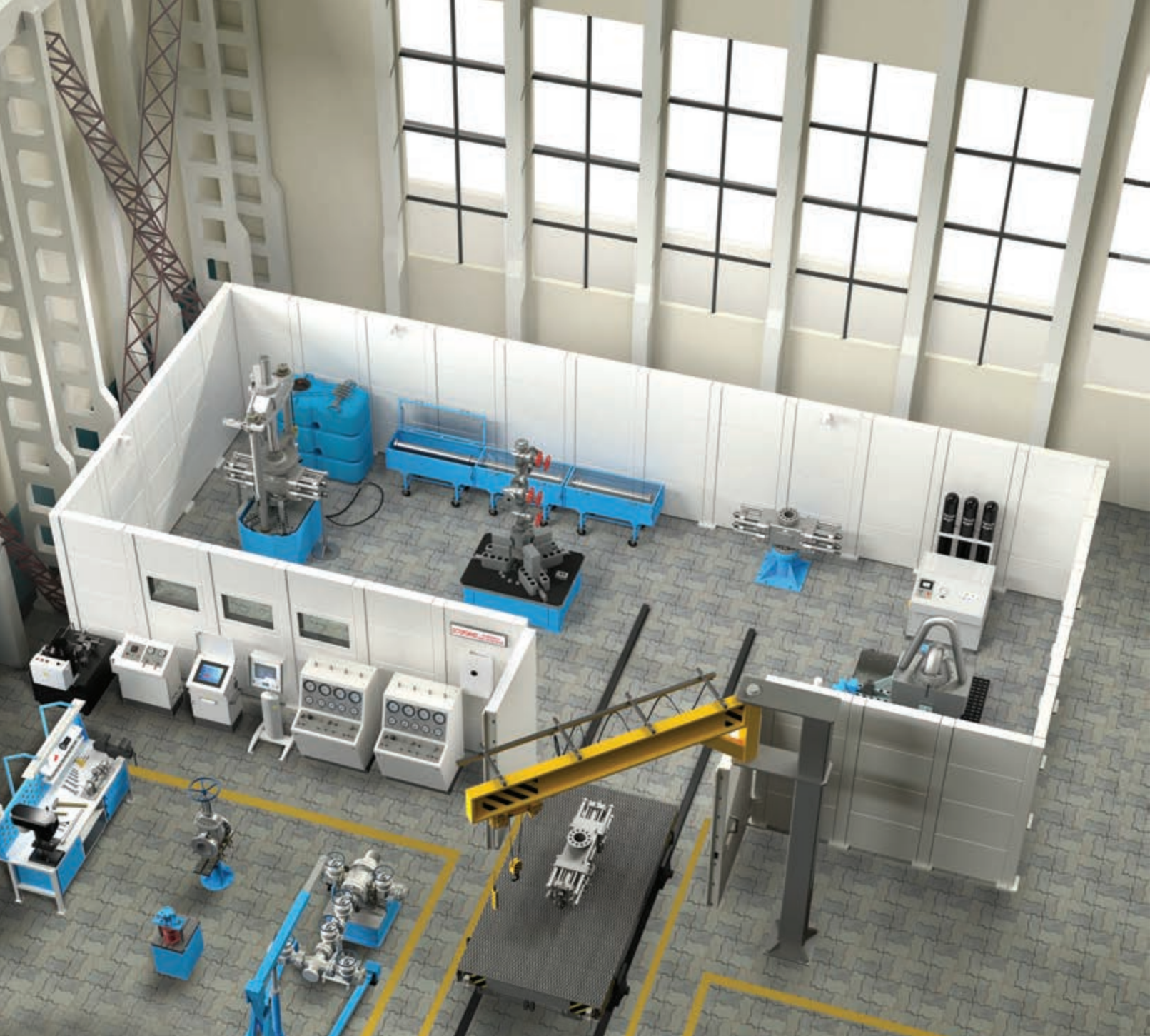

COMPLEX FOR TESTING OF WELLHEAD EQUIPMENT AND BLOWOUT PREVENTERS

VERTICAL TEST BENCH FOR WELLHEAD EQUIPMENT AND BLOWOUT PREVENTERS:

- DN 50...280 mm (2...11")
- DN 100...425 mm (4...17")
- DN 50...425 mm (2...17")

COMPLEX FOR TESTING OF WELLHEAD EQUIPMENT AND BLOWOUT PREVENTERS

PURPOSE:

- shell test;
- valve stem leak-tightness test;
- gate tightness test;
- blowout preventers tightness test.

TESTED VALVES:

- christmas tree valves;
- swivels;
- drilling heads;
- gate valves;
- adapter spools;
- casing heads;
- well flushing equipment set;
- preventers (ram and annular BOPs);
- packers;
- high-pressure hoses;
- wellhead.

**CONFORMS WITH STANDARD:
API 6A.**

TESTING MEDIUM:

- water;
- water with corrosion inhibitor of purity class not rougher than 14 according to GOST 17216 (code 19/16 according to ISO 4406).

Usage of other testing mediums, specified in technical conditions or construction documentation for specific valves, is acceptable upon agreement with REVALVE.



FEATURES:

- Two-sided gate tightness tests do not require tested- valve rearrangement, which significantly reduces the test time.
- Patented design of self-sealing blind flanges excludes axial compression during tests, which ensures test reliability, protects valves against deformation, and extends the valve service life.*
- Accuracy of testing results is provided by controlling and additional gages as well as by computer registration system CRS-M.

EQUIPMENT LAYOUT PLAN

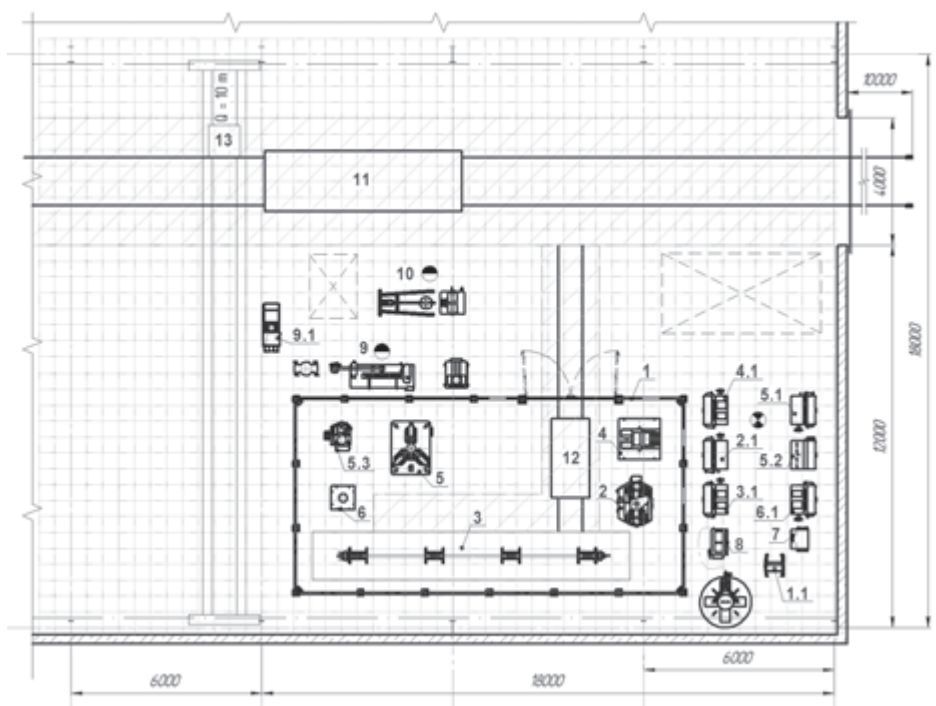

* Upon customer request.

UNIT №1

VERTICAL TEST BENCH FOR WELLHEAD EQUIPMENT AND BLOWOUT PREVENTERS DN 50...280 mm (2...11")

PURPOSE:

- shell test;
- valve stem leak-tightness test;
- gate tightness tests;
- blowout preventers tightness test.

TESTED VALVES:

- wellhead equipment (slab gate valves, spools, tee-bends, cross-heads etc.);
- blowout preventers (small-sized).

CONNECTION TYPE:

- flanged;
- non-flanged.

TESTING MEDIUM:

- water;
- water with corrosion inhibitor of purity class not rougher than 14 according to GOST 17216 (code 19/16 according to ISO 4406).

Usage of other testing mediums, specified in technical conditions or manufacturer documentation for specific valves, is acceptable upon agreement with REVALVE.

FEATURES:

- Bench is equipped with replaceable blind flanges for testing non-flanged valves*. This releases the operation from welding (lock-pin screwing) of the blind flanges to the pipes.
- Side opening upper cross-head simplifies valve installation procedure before testing.
- Use of high-pressure hoses with quick-release couplings reduces test preparation time.

SPECIFICATIONS:

Parameter	UNIT №1
Maximum clamping force, t	220
Motor power, kW	1,1
Actuating medium of hydraulic cylinder clamp	Industrial oil of purity class not lower than 14 according to GOST 17216
Overall dimensions (LxWxH), mm (")	1745x1125x4505 (68x44x177)
Weight, kg	3813

* Upon customer request.

UNIT №1

DN, mm (")	Maximum test pressure, bar (psi)			
	280 (4061)	420 (6090)	700 (10150)	1050 (15225)
50...100 (2...4)				
180...230 (7...9)				
280 (11)				

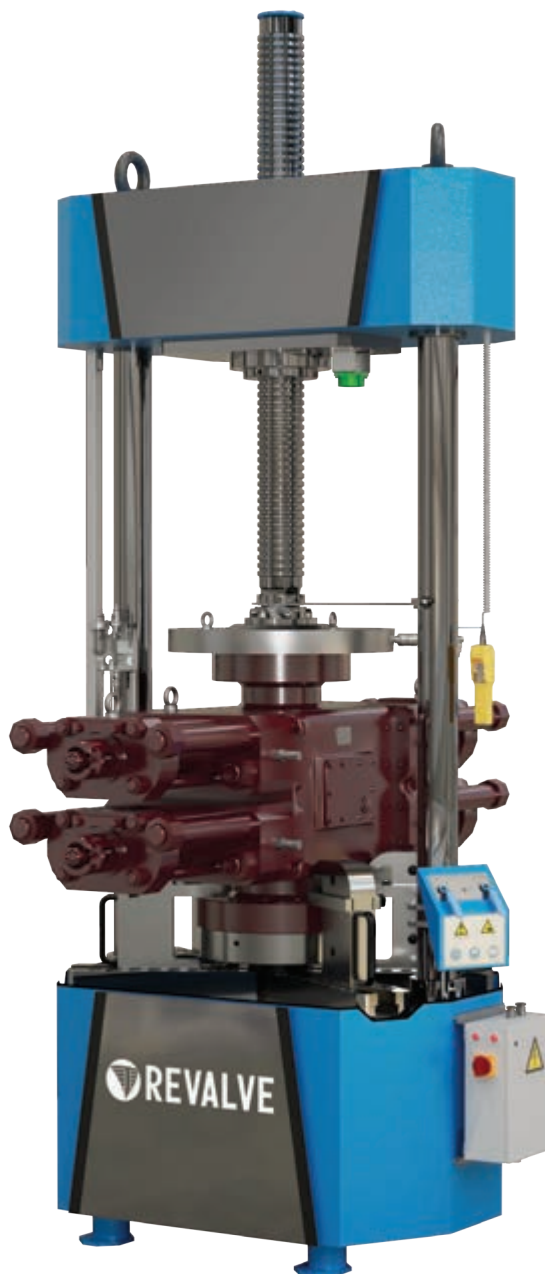

UNIT №4

VERTICAL TEST BENCH FOR WELLHEAD EQUIPMENT AND BLOWOUT PREVENTERS DN 100...425 mm (4...17")

PURPOSE:

- shell test;
- valve stem leak-tightness test;
- gate tightness test.

TESTED VALVES:

- wellhead equipment (slab gate valves, spools, tee- bends, cross-heads etc.);
- blowout preventers (small-sized).

TYPE OF CONNECTION:

- flanged;
- non-flanged.

TESTING MEDIUM:

- water;
- water with corrosion inhibitor of purity class not rougher than 14 according to GOST 17216 (code 19/16 according to ISO 4406).

Usage of other testing mediums, specified in technical conditions or manufacturer documentation for specific valves, is acceptable upon agreement with [REVALVE](#).

UNIT №4

DN, mm (")	Maximum test pressure, bar (psi)				
	280 (4061)	420 (6090)	700 (10150)	1050 (15225)	1400 (20305)
100 (4)					
180 (7)					
230 (9)					
280 (11)					
350 (14)					
425 (17)					



SPECIFICATIONS:

Parameter	UNIT №4
Diameter of the clamping flange, mm (")	425 (17)
Overall dimensions (LxWxH), mm (")	740x740x500 (29x29x20)

UNIT №5

VERTICAL TEST BENCH FOR WELLHEAD EQUIPMENT AND BLOWOUT PREVENTERS DN 50...425 mm (2...17")

PURPOSE:

- wellhead equipment and blowout preventers;
- christmas tree and injection tree valves.

TESTED VALVES:

- christmas tree;
- injection tree;
- blowout preventers.

TYPE OF CONNECTION:

- flanged.

TESTING MEDIUM:

- water;
- water with corrosion inhibitor of purity class not rougher than 14 according to GOST 17216 (code 19/16 according to ISO 4406).

Usage of other testing mediums, specified in technical conditions or manufacturer documentation for specific valves, is acceptable upon agreement with REVALVE.



**CONFORMS WITH STANDARD:
API 6A.**

FEATURES:

- Bench allows to perform tests without axial compression, which protects the valves against deformation and ensures test reliability.
- Floor, pit and safety fence installations are offered as options.
- Clamping unit is equipped with powerful hydraulic cylinder installed in the basement of the test bench. Hydraulic system of the clamping unit use oil as operating medium, which extends the bench service life.
- Fast clamping of the tested valve is provided with pneumatic cylinders providing synchronized travel of the clamps.
- Optional use of hydraulic clamping unit with self-sealing adapters and medium separator allows to achieve even wider range of tested valves.

OPTIONAL:

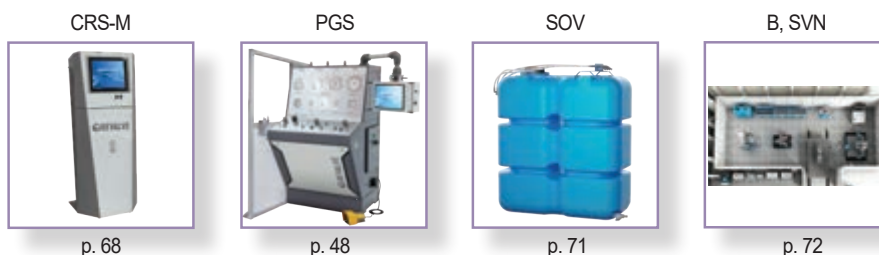

UNIT №5

VERTICAL TEST BENCH FOR WELLHEAD EQUIPMENT AND BLOWOUT PREVENTERS
DN 50...425 mm (2...17")

UNIT №5

Maximum test pressure, bar (psi)

DN, mm (")	280 (4061)	420 (6090)	700 (10150)	1050 (15225)
50...230 (2...4)				
280 (11)				
350 (14)				
425 (17)				



SPECIFICATIONS:

Parameter	UNIT №5
Maximum clamping force, t	700
Min./max. diameter of clamped flange, mm (")	165/705 (6/28)
Maximum pressure of the clamping system, bar (psi)	340 (4930)
Air pressure, supplied to pneumatic cylinders providing travel of the clamps, bar (psi)	4...6 (58...87)
Overall dimensions (LxVxH), mm (")	1660x1220x1340 (66x49x53)
Weight, kg (bench)	3855

CRS-M

COMPUTER REGISTRATION SYSTEM

PURPOSE:

- tsystem is designed for measuring pressure, test medium leakage through valve gate, temperature of test medium and ambient air, HDD saving and printing out test protocols (testing in accordance with API, ANSI FCI, ISO, GOST, DIN and other standards).

TEST TYPES:

- liquid and gas shell test;
- liquid and gas seat leakage test of shut-off valves;
- liquid and gas seat leakage test of safety valves;
- liquid and gas tests of the well-head and anti-blowout equipment by the working pressure;
- safety valve adjustment (measuring valve full lift, set and reseating pressure).



DESIGN:

- stationary design;
- mobile design;
- integrated design.

FEATURES:

- No human influence on the test results. Automatic recording of the test results. Integration into the company network is possible.
- High reliability and accuracy of the results are ensured by the pressure and leakage gauges, as well as industrial computer.
- Software package is made for easy operation with the system, and allows to input necessary valve data as: DN, PN, test standard, types of test, operator and manufacturer details, sensor calibration parameters. When testing process has been finalized CRS-M system generates a report with real time testing conditions explicated in a graphics. Reports are saved in archive on internal HDD.

FUNCTIONS:

1. Leakage measurement by bubbles (drops) and actual volume during the shut-off valve tests and the leakage class (determination during hydraulic and pneumatic tests. For measurement of leakages according to ANSI FCI 70.2 (Class II-VI) ANSI B16.104 unit requires upgrade to CRS-M-R version.
2. Measuring of the test-medium pressure during hydraulic and pneumatic tests of the shut-off and safety valves with maximum permissible error of 0.4% or smaller.
3. Test medium and surrounding air temperature measurement during hydraulic tests. (Not included in CRS-M-M.)
4. Pressure measurement at the time of popping, full opening, and reseating of the safety valve gate during the valve test and adjustment.
5. Graphic output of the test results.
6. Electronic and paper saving and storing of the test protocols with possible data transmission.
7. Test data base development for each item.
8. Test result printout.
9. Leakage measurement during the control valve tests (when using additional flowmeters).

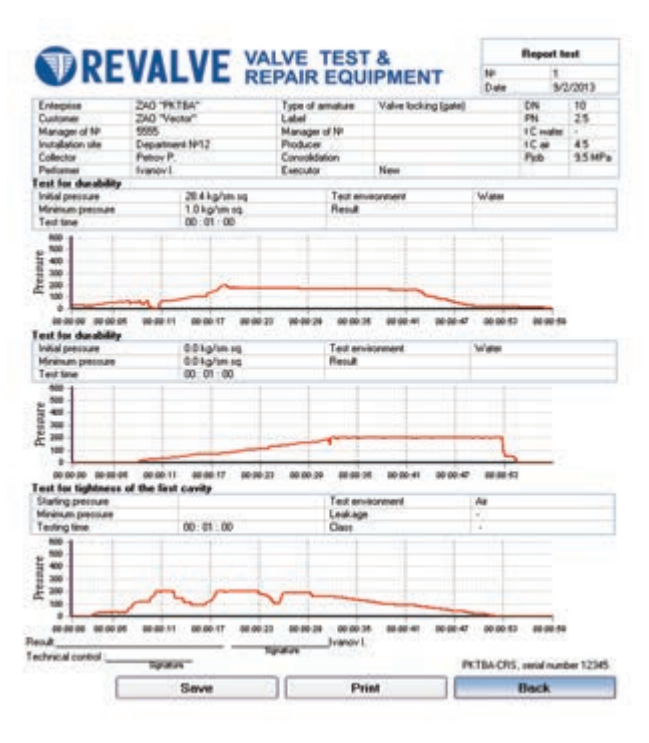

SPECIFICATIONS:

Parameter	CRS-M
Operating medium	water, gas*
Maximum measured test pressure, bar (psi)	1600 (23206)
Maximum measured leakage volume for water/air, cm ³ /min (fl oz)	12/15 (0,4 / 0,5)
Reduced pressure measurement error, %	±0,4
Reduced leakage measurement error, %	±3,0
Test medium and surrounding air temperature measurement range, C° (F°)	0...+60 (+32...+140)
Absolute error of the temperature measurement, C° (F°)	±1 (±34)
Power supply, V/Hz	230/50 (110/60)
Power consumption, kW	0,6
Overall dimensions	depending on system design

* Requirements for water: in 100 cubic centimeters (milliliters) (3,38 fl oz) of water should contain no more than 400 solid particles: size from 50 up to 100 microns (0,002-0,004"). Requirements for air: size of solid particles not more than 40 microns (0,002").

UK AUTOMATED COMPRESSOR UNIT

PURPOSE:

- pressure source for high pressure pneumatic tests of valves and pressure vessels;
- independent pressure source.

COMPLETE SET:

- air compression and supply unit:
 - compressor;
 - cylinder set 3x50 l (3x13gl), 2x50 l (2x13gl);
 - monitoring, adjustment, and control unit;
 - piping and automatic equipment system;
 - additional available boosters (in UK-2 and UK-3).
- spare parts, tools, and accessories.



Pressure up to 400 bar (5800 psi)

FEATURES:

- High pressure compressor unit with 150 l receiver, will provide you with long term reliable operation of testing unit, instead of air boosters which require monthly overhauling, and replacing of piston rings, which requires time and skilled operators.
- Compressor unit is specially designed for use with test bench, which reduces its cost compared to large compressors supplying the required pressure.
- Compressor unit is designed for long-term continuous operation.
- Unit control system automatically maintains the cylinder pressure within the specified limits and ensures unit shutdown in case of emergency.
- It has 2 individually adjusted high- and low-pressure output lines.
- Compressed air backup is up to 130 / 100 l (34x26 gl).
- Stepwise air volume adjustment in the cylinders 55-110-150 l (13-26-40 gl) allows to reduce the high pressure generation time.

SPECIFICATIONS:

Parameter	UK-1	UK-2	UK-3	UK-3M
Maximum pressure, bar (psi)	64 (928)	200 (2900)	350 (5075)	400 (5800)
Compressor capacity normalized to standard conditions, nl/min		250		300
Pressure buildup time, min:				
- up to maximum pressure in a 50 l (13 gl) receiver;	15	40	70	850
- up to maximum pressure in a one-liter (0.3 gl) tank.	0,3	0,8		1,75
Receiver volume, l (gl)		150 (40)		100 (26)
Motor power, kW		5,5		10,0
Power supply, V/Hz			400/50	
Overall dimensions (LxWxH), mm (") (compressor / receiver)		1340x940x1300 (48x64x84) / 1296x355x1981 (51x14x78)		710x1250x830 (28x49x33) / 910x355x1985 (36x14x78)
Weight, kg		562	608	500

SOV

RECYCLING WATER SUPPLY STATION

PURPOSE:

- autonomous recycling process water supply station for test benches and pneumohydraulic stations included in composition thereof as well as for other units using process water.

ADVANTAGES:

- Operation in automated mode with maintained set output water pressure.
- Unit provides water supply for consumers through two lines with separate adjustment of pressure for each one.
- Unit stops automatically when water level in the tank reaches minimum.
- Modular structure of the unit allows to increase SOV tank volume up to 12 m³.*
- Provides hydraulic testing without main process water supply line in the workshop.
- Water drainage from several units (up to 4) to the tank. Provides closed cycle of water recirculation.
- Tank may be placed at 10 m distance away from the control panel.
- Possible use of water with corrosion inhibitors and other.*



VU

VACUUM SYSTEM

PURPOSE:

- air drainage from tested pipeline valves clamped on the test bench before filling with process water. Recommended for use with horizontal test benches.

FEATURES:

- Provides significant reduction of time necessary for filling of tested valves with water. Recommended to be used with horizontal clamping units in case tested valves are not equipped with relieve valves.
- High degree of vacuumizing (up to -0.95 bar).
- Essential for horizontal bench for testing of large inner diameter valves and fittings from DN 400 mm (16") and higher.
- Equipped with automated control system which allows switching off the unit when the required level of vacuumization is reached.
- Can be used as vacuum creation unit in set with PGS unit in other fields of applications such as breather valves testing.
- Compatible with all types of test benches from REVALVE product range as well as for use as a component with other manufacturer's test bench.



* Upon customer request.

B

SAFETY FENCE FOR HIGH PRESSURE TESTING

PURPOSE:

- provision of safety protection in case of tested valves or connecting elements depressurization during hydraulic and pneumatic testing.

COMPLETE SET:

- columns;
- panels (with or without window);
- swing gates (sliding*);
- sliding roof*;
- lighting/warning panel;
- electrical cabinet;
- pneumatic safety locking device.*

TYPICAL SIZES (LXWXH):*

- 4x4x2,5 m;
- 4x6x2,5 m;
- 6x10x2,5 m;
- 9x9x2,5 m.

OPTIONAL:

- video control system (SVN).

SVN



FEATURES:

- Set of modules allows mounting of safety fence of various types and sizes with possible placement of gates at various sides.
- Panels of safety fence are provided with viewing windows of certified armored glass.
- Safety fence is equipped with the locking mechanism of entrance gates during gas testing.
- Armored protection is mounted at the site. Columns are installed at foundations using foundation (anchor) bolts.
- In order to provide electrical safety panels and gates are equipped with grounding bolts.

SPECIFICATIONS:

Parameter	B
Height, mm (")	2500 (96)
Blank panel width, mm (")	1000 (40)
Width of blank panel with windows, mm (")	1000 (40)
Clear swing gates width, mm (")	1640x2640 (66x104)
Maximum length of armored wall with open gates, mm (")	6000 (236)

* Upon customer request.

SI-PRA

TEST UNIT FOR TESTING OF CONTROL VALVE ACTUATORS

PURPOSE:

- operation testing, valve closure element harmonization and insensitivity adjustment for valves with diaphragm actuators and actuators of control valves with pneumatic and electric control.

SPECIFICATIONS:

Parameter	SI-PRA
Air pressure control range, bar (psi):	
- channel I;	from 0 to 4 (58)
- channel II.	from 0 to 7 (102)
Pressure gauge accuracy rating, at least	0,6
Adjustment range of current acc. to load, not exceeding 1kOhm, mA	from 0 to 20
Adjustment range of voltage acc. to load, at least 3 kOhm, V	from 0 to 30
Fixed values:	
- of current acc. to load, not exceeding 1kOhm, mA;	4, 8, 12, 16, 20
- voltage acc. to load, at least 15 Ohm, V	24
Power voltage of the tested products, V/W	24/20, 48/20
Milliammeter and voltmeter accuracy rating, at least	0,5
Air pressure supplied to the bench, bar (psi), at least	7,5 (109)*
Supply power, V/Hz	230/50
Overall dimensions, (LxWxH), mm (*)	600x700x1700 (24x28x68)
Weight, kg	120

* Allows to supply air with lower pressure to narrow the range of air control in the channel II.



BR, MIP-W, MIP-A

LEAKAGE MEASURING UNIT FOR CONTROL VALVES

PURPOSE:

- measuring of leakages through the gate element of control valve during testing with air.

FEATURES:

- High precision and visibility when testing for gate tightness with air.
- Wide range of measured leakage allows testing of control valves with tightness class II-VI as per (ANSI/FCI 70-2).
- Unit allows to connect additional flow sensors to register the leakages by using computer registration system CRS-M.*
- Mobile design of the unit allows to move it between the different benches, depending on the need for testing of control valves.
- Built-in filter eliminates the need to clean the flowmeters in contact with foreign particles from the tested valves.

SPECIFICATIONS:

Parameter	BR	MIP-W	MIP-A
Operation medium	air	water according to GOST R 51232*	air
Relative accuracy, %		±5,0**	
Range of airflow rate measurement	0...26,5 cm ³ /min (bubble counter) 0,021...816 nl/min (leakage measuring unit) at 20°C	0,0072...27 nl/min	0,01...1000,0 nl/min
Operation conditions:			
- ambient air temperature, °C (°F);	from +5 (+41) to +40 (+104)		
- relative humidity (at + 25 °C)%.	30...80		
Overall dimensions (LxWxH), mm (*)	700x705x1870 (27x28x74)	680x320x840 (27x13x33)	655x225x690 (26x9x27)
Weight, kg	45	45	33

* Upon customer request.

** Except bubble chamber.



BR



MIP-W



MIP-A

MG

HYDRAULIC DRIVE UNIT

PURPOSE:

- pressurized oil supply unit, with pressure rate adjustment by safety valve settings into system, for various hydroficated equipment.

COMPLETE SET:

- hydraulic tank volume 160 l;
- pumping unit;
- control system;
- filters (suction, inlet, drain);
- safety valves;
- gauge;
- heat exchange unit;
- oil level indicator.

FEATURES:

- Large volume of hydraulic tank with the possibility of refitting* allows to perform a wide range of operations.
- Fixed and remote control to enable/disable the unit.
- Built-in sensor shuts off the unit automatically when oil achieves a minimum level.
- Air heat exchange unit with integrated temperature sensor provides long smooth operation of the hydraulic drive unit due to oil cooling.
- Pollution indication of a drain filter allows to replace the filter element in time for guaranteed oil purity.
- Gear pump is oil-immersed to reduce noise and to provide favorable conditions for the unit operation.



SPECIFICATIONS:

Parameter	MG
Hydraulic tank rated capacity, dm ³	155
Pumping unit type	gear
Rated pumping capacity, l/min	14
Pumping unit motor power, kW	7,5
Supply voltage, V/Hz	400/50
Min. / max. hydraulic drive unit pressure, bar (psi)	5 / 210 (72,5 / 3046)
Overall dimensions, (LxWxH), mm (")	1182x628x1065 (46x24x42)
Weight without oil, kg, not exceeding	300

* Upon customer request.

MSSH

MUFFLER FOR HIGH PRESSURE PSV GAS TESTING

PURPOSE:

- reducing noise and providing exhaust filtration during pneumatic testing of safety valves DN 50...300 mm (2...12").

FEATURES:

- Using the muffler during operation provides safety valve noise level reduction to a safe level.
- Provides filtration of the exhaust air from safety valve by reducing the mechanical impurities (dust, particles, scale, etc).
- Specially designed on a mobile stand with height adjustment.
- Adapters kit allows you to connect unit to almost any safety valve with DN up to 300 mm (12") (more than DN 300 mm (12") - on request).

SPECIFICATIONS:

Parameter	MSSH
Height adjustment (on the axis of the transition pipe), mm (")	876...1436 (34...57)
Weight, kg (reduction noise/set of replacement parts)	294/24



OUR CERTIFICATES



CONTACT:

Export Department

Tel.: +7 (8412) 200-201

E-mail: sales@revalve.com

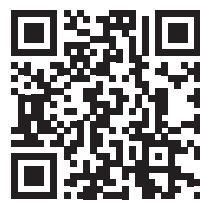

VIRTUAL 3D TOUR OF THE WORKSHOP

ADDRESS:

75 Pobedy Ave., Penza, 440060, Russia

Please note! We reserve the rights to change characteristics of equipment during modernization.
To receive the last updated information, please refer to our experts or fill out the online form.
We will send you the Questionnaire list to help you choose equipment that matches your needs.
We appreciate your confidence in us!

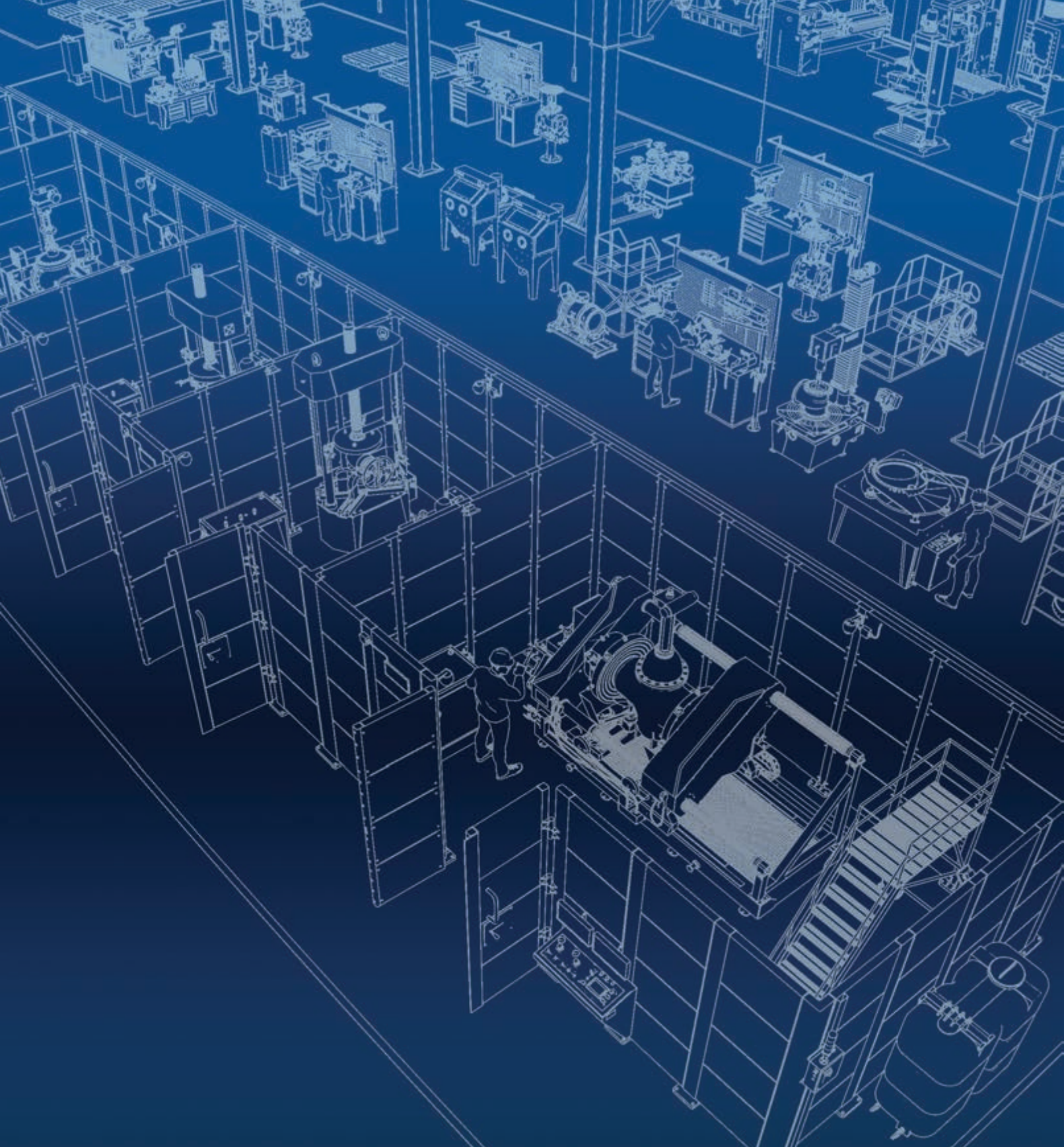

REVALVE by «PKTBA» CJSC

75 Prospekt Pobedy, Penza, 440060, Russia

Tel./fax: +7 (8412) 200-201

e-mail: sales@revalve.com

www.revalve.com